

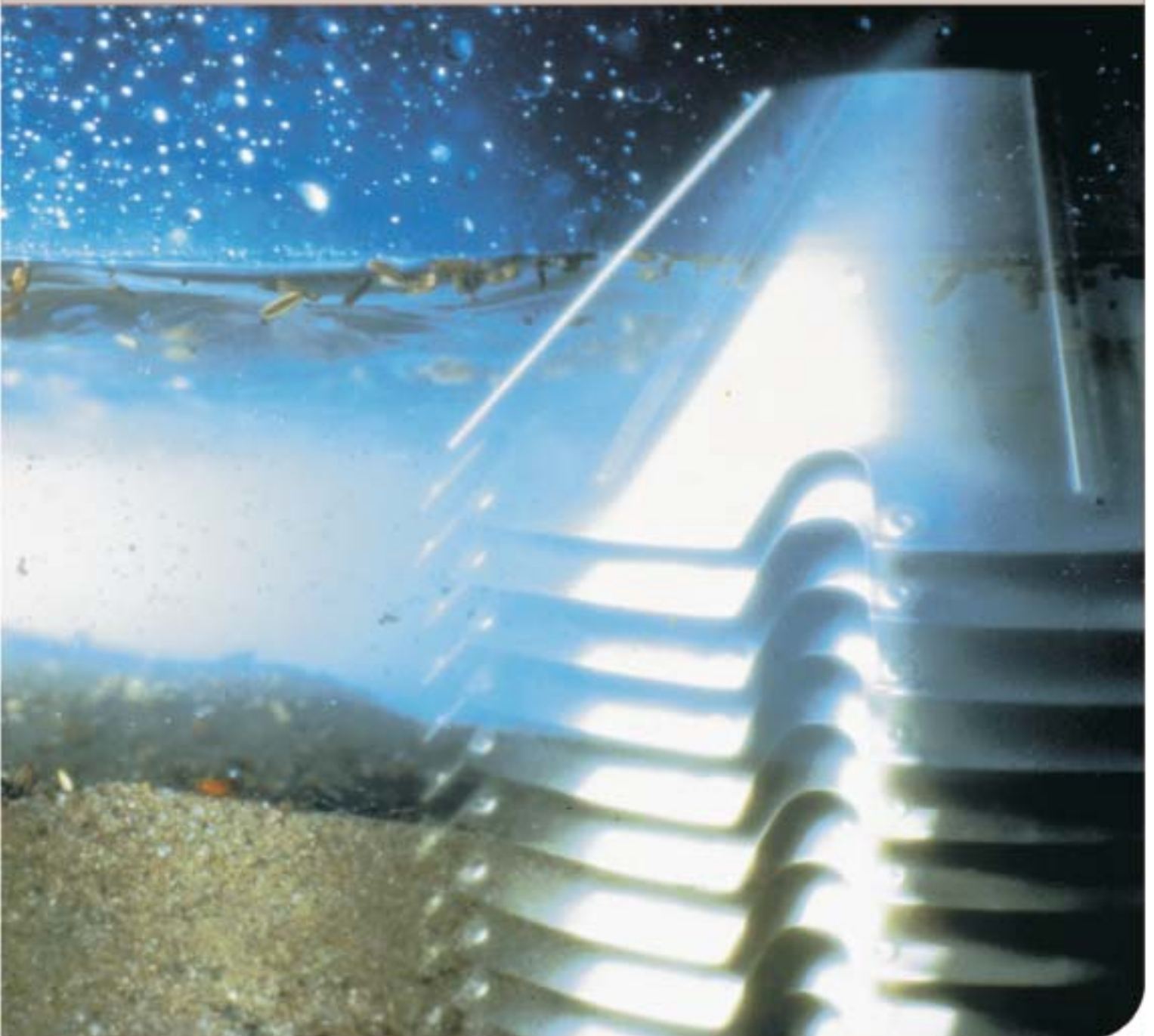

Separator Manual
High Speed Separator

P 605



Published By:

Alfa Laval Tumba AB
SE-147 80 Tumba, Sweden

Telephone: +46 8 530 650 00
Telefax: +46 8 530 310 40

© Alfa Laval Tumba AB 08 June 2005

This publication or any part there of may not be reproduced or transmitted by any process or means without prior written permission of Alfa Laval Tumba AB.

Contents

1	Safety Instructions	7
1.1	Warning signs in text	12
1.2	Environmental issues	13
1.3	Requirements of personnel	14
2	Read this first & Separator Basics	15
2.1	Read This First	16
2.2	Design and function	18
2.3	Definitions	26
3	Service Instructions	27
3.1	Periodic maintenance	28
3.2	Maintenance Logs	31
3.3	Check points at Intermediate Service	36
3.4	Check points at Major Service	48
3.5	3-year service	51
3.6	Lifting instructions	52
3.7	Cleaning	53
3.8	Oil change	56
3.9	Vibration	58
3.10	General directions	60
4	Dismantling/Assembly	65
4.1	Inlet/outlet and bowl	68
4.2	Bowl spindle and frame	86
4.3	Friction coupling	100
4.4	Flat belt and tightener	107
4.5	Oil filling device	112

4.6	Water tank	113
4.7	Brake	113
4.8	Frame feet	115
5	Technical Reference	117
5.1	Product description	118
5.2	Technical data	119
5.3	Connection list	120
5.4	Basic size drawing	122
5.5	Interface description	124
5.6	Water quality	132
5.7	Lubricants	133
5.8	Drawings	140
5.9	Storage and installation	151
5.10	Protection and storage of goods	152
6	Operating	161
6.1	Operating routine	162
6.2	Before first Start	162
6.3	Start after a service	164
6.4	After Safety Stop	171



Study instruction manuals and observe the warnings before installation, operation, service and maintenance.

Not following the instructions can result in serious accidents.

In order to make the information clear only foreseeable conditions have been considered. No warnings are given, therefore, for situations arising from the unintended usage of the machine and its tools.



1 Safety Instructions



The centrifuge includes parts that rotate at high speed. This means that:

- Kinetic energy is high
- Great forces are generated
- Stopping time is long



Manufacturing tolerances are extremely fine. Rotating parts are carefully balanced to reduce undesired vibrations that can cause a breakdown. Material properties have been considered carefully during design to withstand stress and fatigue.

The separator is designed and supplied for a specific separation duty (type of liquid, rotational speed, temperature, density etc.) and must not be used for any other purpose.

Incorrect operation and maintenance can result in unbalance due to build-up of sediment, reduction of material strength, etc., that subsequently could lead to serious damage and/or injury.

The following basic safety instructions therefore apply:

- **Use the separator only for the purpose and parameter range specified by Alfa Laval.**
- **Strictly follow the instructions for installation, operation and maintenance.**
- **Ensure that personnel are competent and have sufficient knowledge of maintenance and operation, especially concerning emergency stopping procedures.**
- **Use only Alfa Laval genuine spare parts and the special tools supplied.**





Disintegration hazards

- When power cables are connected, always check direction of motor rotation. If incorrect, vital rotating parts could unscrew.
- If excessive vibration occurs, **stop** separator and **keep bowl filled** with liquid during rundown.
- Use the separator only for the purpose and parameter range specified by Alfa Laval.
- Check that the gear ratio is correct for power frequency used. If incorrect, subsequent overspeed may result in a serious break down.
- Welding or heating of parts that rotate can seriously affect material strength.
- Wear on the large lock ring thread must not exceed safety limit. ϕ -mark on lock ring must not pass opposite ϕ -mark by more than specified distance.
- Inspect regularly for **corrosion** and **erosion** damage. Inspect frequently if process liquid is corrosive or erosive.

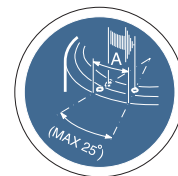
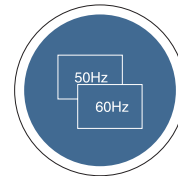
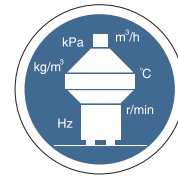
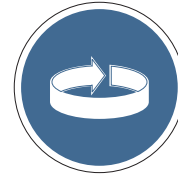

S01512F1

S01512N1

S01512P1

S01512L1

S0151241

S01512G1

S01512H1



Entrapment hazards

- Make sure that rotating parts have come to a **complete standstill** before starting **any** dismantling work.
- To avoid accidental start, switch off and lock power supply before starting **any** dismantling work.

Assemble the machine **completely** before start. **All** covers and guards must be in place.



S0151201

S0151261



Electrical hazard

- Follow local regulations for electrical installation and earthing (grounding).
- To avoid accidental start, switch off and lock power supply before starting **any** dismantling work.



S0151271



Crush hazards

- Use correct lifting tools and follow lifting instructions.

Do **not** work under a hanging load.



S01512M1

S01512Y1



Noise hazards

- Use ear protection in noisy environments.



S0151281



Burn hazards

- Lubrication oil and various machine surfaces can be hot and cause burns.



S01512A1



Skin irritation hazards

- When using chemical cleaning agents, make sure you follow the general rules and suppliers recommendation regarding ventilation, personnel protection etc.
- Use of lubricants in various situations.



S01512D1



Cut hazards

- Sharp edges on bowl discs and threads can cause cuts.



S01512B1



Flying objects

- Risk for accidental release of snap rings and springs when dismantling and assembly.



S01512C1



Health hazard

- Risk for unhealthy dust when handling friction blocks/pads. Use a dust mask to make sure not to inhale any dust.

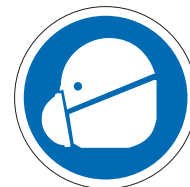

S01512V1



1.1 Warning signs in text

Pay attention to the safety instructions in this manual. Below are definitions of the three grades of warning signs used in the text where there is a risk for injury to personnel.



DANGER indicates an imminently hazardous situation which, if not avoided, will result in death or serious injury.



WARNING indicates a potentially hazardous situation which, if not avoided, could result in death or serious injury.



CAUTION indicates a potentially hazardous situation which, if not avoided, may result in minor or moderate injury.



NOTE indicates a potentially hazardous situation which, if not avoided, may result in property damage.



1.2 Environmental issues

Unpacking

Packing material consists of wood, plastics, cardboard boxes and in some cases metal straps.

Wood and cardboard boxes can be reused, recycled or used for energy recovery.

Plastics should be recycled or burnt at a licensed waste incineration plant.

Metal straps should be sent for material recycling.

Maintenance

During maintenance oil and wear parts in the machine are replaced.

Oil must be taken care of in agreement with local regulations.

Rubber and plastics should be burnt at a licensed waste incineration plant. If not available they should be disposed to a suitable licensed land fill site.

Bearings and other metal parts should be sent to a licensed handler for material recycling.

Seal rings and friction linings should be disposed to a licensed land fill site. Check your local regulations.

Worn out or defected electronic parts should be sent to a licensed handler for material recycling.



1.3 Requirements of personnel

Only **skilled** or **instructed** persons are allowed to operate the machine, e.g. operating and maintenance staff.

- **Skilled person:** A person with technical knowledge or sufficient experience to enable him or her to perceive risks and to avoid hazards which electricity/mechanics can create.
- **Instructed person:** A person adequately advised or supervised by a skilled person to enable him or her to perceive risks and to avoid hazards which electricity/mechanics can create.

In some cases special skilled personnel may need to be hired, like electricians and others. In some of these cases the personnel has to be certified according to local regulations with experience of similar types of work.

2 Read this first & Separator Basics

Contents

2.1 Read This First	16
2.2 Design and function	18
2.2.1 Application	18
2.2.2 Design	19
2.2.3 Outline of function	19
2.2.4 Separating function	20
2.2.5 Sludge discharge function	22
2.2.6 Power transmission	24
2.2.7 Sensors and indicators	25
2.3 Definitions	26

2.1 Read This First

This manual is designed for operators, maintenance personnel and service engineers working with the Alfa Laval S 300 separator.

If the separator has been delivered and installed by Alfa Laval as a part of a processing system, this manual should be viewed as part of the System Documentation. Study carefully all instructions in any System Documentation.

In addition to this Separator Manual a Spare Parts Catalogue, SPC is supplied.

The Separator Manual consists of:

Safety Instructions

Pay special attention to the safety instructions for the separator. Accidents causing damage to equipment and/or serious injury to persons or personnel can result if the safety instructions are not followed.

Basic Principles of Separation

This chapter describes the purpose of separation and separation principles.

Design and function

This chapter contains a description of the separator.

Operating Instructions

This chapter contains operating instructions for the separator only.

Service, Dismantling, Assembly

This chapter gives instructions for the maintenance procedures. It also contains step-by-step instructions for dismantling and assembly of the separator for service and repair.

Fault Finding

Refer to this chapter if the separator functions abnormally.

If the separator has been installed as a part of a processing system, always refer to the trouble-tracing instructions, in the System Documentation.

Technical Reference

This chapter contains technical data concerning the separator and drawings.

Installation

This chapter contains specifications and recommendations concerning separator installation.

NOTE

A complete reading of this manual by personnel in contact with the machine is essential to safety.

Do not allow personnel to clean, assemble, operate or maintain the separator until they have read and fully understood this manual.

Ensure that all personnel who operate and service the separator are well-trained and knowledgeable concerning the machine and the work to be carried out.

2.2 Design and function

2.2.1 Application

The P 605 is a high-speed centrifugal separator intended for marine and land applications. It is specifically designed for cleaning of mineral oils from water and solid particles (sludge). The cleaned oil is discharged continuously, while the sludge is discharged at intervals.

The separator handles the following types of lubricating oils and low viscosity fuel oils:

- Distillate, viscosity 1,5 - 5,5 cSt/40 °C
- Marine diesel oil, viscosity 13 cSt/40 °C
- Intermediate fuel oil and heavy fuel oil (viscosity 30-380 cSt/50 °C)
- Lubricating oil of R & O type, detergent or steam turbine.

The separator can be operated either as a purifier or as a clarifier. When operated as a purifier the separator discharges the separated water continuously.

When the oil contains only small amounts of water the separator is operated as a clarifier, discharging the water together with the solid particles.

The separator has to be installed together with devices for control of its operation.

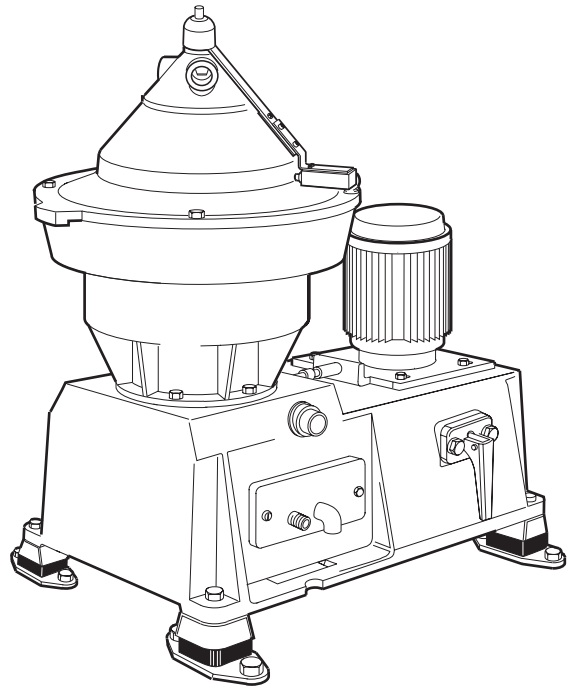

The P 605 separator.

G046488 1



Disintegration hazards

Use the separator only for the purpose and parameters (type of liquid, rotational speed, temperature, density etc.) specified in chapter **5 Technical Reference, page 117** and in the Purchase Order documents.

Consult your Alfa Laval representative before any changes outside these parameters are made.

2.2.2 Design

The P 605 separator comprises a frame consisting of the frame lower part, the intermediate part and the frame top part with a frame hood.

The separator bowl (C) is driven by an electric motor (A) via a flat-belt power transmission (D) and bowl spindle (B). The motor drive is equipped with a friction coupling to prevent overload.

The bowl is of disc type and hydraulically operated at sludge discharges. The hollow bowl spindle (B) features an impeller which pumps closing water from a built-in tank to the operating system for sludge discharge.

The main inlets and outlets are shown with their connection numbers in the illustration. The connections are listed in chapter 5 **Technical Reference**, page 117, where also the basic size drawing can be found.

2.2.3 Outline of function

The separation process takes place in the rotating bowl. Unseparated oil is fed into the bowl through the inlet (201). The oil is cleaned in the bowl and leaves the separator through the outlet (220) via a paring chamber.

Impurities heavier than the oil are collected in the sludge space at the bowl periphery and removed automatically at regular intervals.

Permissible pressures and operating conditions are specified in chapter 5 **Technical Reference**, page 117.

The processing parts of the separator are shown in the illustration on next page.

There are no contacting surfaces between process rotating parts (the bowl) and stationary parts (inlet, outlet, feed devices), and the interfacing surfaces are not sealed. As the separation process is carefully balanced regarding pressures and fluid levels, any leakages will not occur as long as the correct running conditions are maintained.

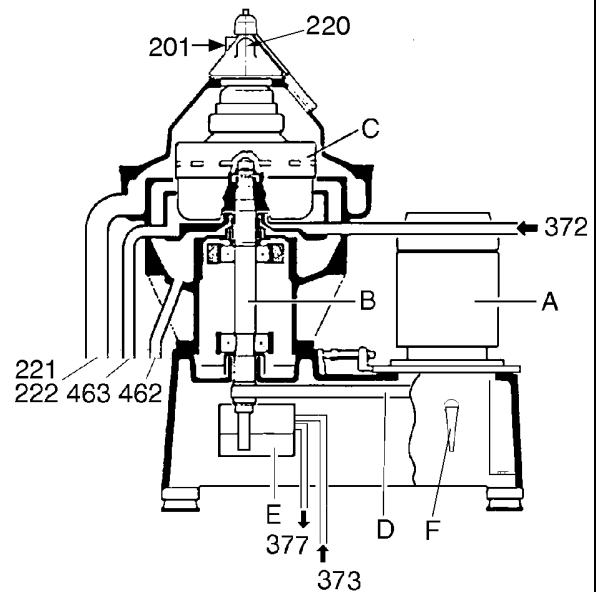

Sectional view
Main parts, inlets and outlets

- A Electric motor
- B Bowl spindle
- C Bowl
- D Flat belt
- E Closing water tank
- F Brake handle

- 201 Oil inlet
- 220 Oil outlet
- 221, 222 Water/sludge outlet
- 372 Opening water inlet
- 373 Bowl closing water
- 377 Overflow
- 462 Drain
- 463 Drain

2.2.4 Separating function

Liquid flow

Separation takes place in the separator bowl to which unseparated oil is fed through the inlet pipe (201). The oil is led by the distributor (T) towards the periphery of the bowl.

When the unseparated oil reaches the slots of the distributor, it will rise through the channels formed by the disc stack (G) where it is evenly distributed into the disc stack.

The oil is continuously separated from water and sludge as it will flow towards the center of the bowl. When the cleaned oil leaves the disc stack it rises upwards and enters the paring chamber. From there it is pumped by the paring disc (F) and leaves the bowl through the outlet (220).

Separated sludge and water move towards the bowl periphery. In purification separated water rises along the outside of the disc stack, passes from the top disc channels over the edge of the gravity disc (K) and leaves the bowl into the common sludge and water outlet (221) of the separator.

Heavier impurities are collected in the sludge space (H) outside the disc stack and are discharged at intervals through the sludge ports (L).

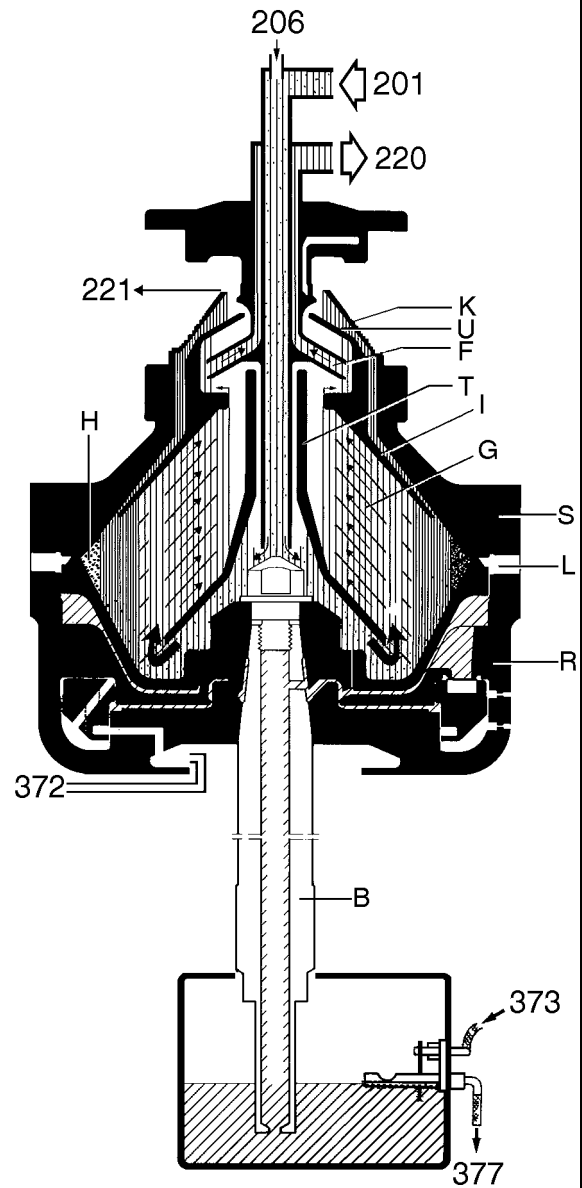

- | | | | |
|---|----------------------|-----|---|
| F | Paring disc | 201 | Oil inlet |
| G | Disc stack | 206 | Water seal and displacement water inlet |
| H | Sludge space | 220 | Oil outlet |
| I | Top disc | 221 | Water outlet |
| K | Gravity disc | 372 | Opening water inlet |
| L | Sludge ports | 373 | Bowl closing water |
| R | Bowl body | 377 | Overflow |
| S | Bowl hood | | |
| T | Distributor | | |
| U | Paring chamber cover | | |

G 0112361

Water seal in purification

To prevent the oil from passing the outer edge of the top disc (I) and escaping through the water outlet (221), a water seal must be provided in the bowl. This is done by filling the bowl with water through the water inlet (206), before unseparated oil is supplied. When oil feed is turned on the oil will force the water towards the bowl periphery and an interface (X) is formed between the water and the oil. The position of the interface is determined by the size of gravity disc (K).

Displacement of oil

To avoid oil losses at sludge discharge, displacement water is fed to the bowl.

Prior to a discharge the oil feed is stopped and displacement water added through the water inlet (206). This water changes the balance in the bowl and the interface (X) moves inwards to a new position (Y), increasing the water volume in the sludge space. When the sludge discharge takes place sludge and water alone are discharged.

Sludge discharge occurs while the displacement water is still flowing. A new water seal will therefore establish immediately afterwards. The oil feed is then turned on again.

Gravity disc

In the purification mode, the position of the interface (X) can be adjusted by replacing the gravity disc (K) for one of a larger or smaller size.

A gravity disc of a larger size will move the interface towards the bowl periphery, whereas a disc of a smaller size will place it closer to the bowl centre.

The correct gravity disc is selected from a nomogram, see [5.7.2 Alfa Laval lubricating oil groups, page 134](#).

The sizes of the gravity discs are normally stamped on the discs.

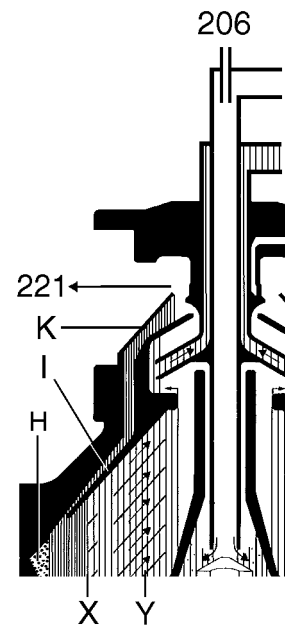

Principle of liquid seal and displacement water in purification

- H Sludge space
- I Top disc
- K Gravity disc
- X Normal interface position
- Y Interface position just before discharge

206 Water inlet
221 Water outlet

Clarifier disc

In the clarification mode, the gravity disc is replaced by a clarifier disc which seals off the water outlet. In this case no water seal is required and consequently there is no oil/water interface in the bowl. The clarifier disc is an optional disc with a hole diameter of 40 mm. This disc is not shown in the nomograms.

2.2.5 Sludge discharge function

Sludge is discharged through a number of ports (L) in the bowl wall. Between discharges these ports are covered by the sliding bowl bottom (M), which forms an internal bottom in the separating space of the bowl. The sliding bowl bottom is pressed upwards against a sealing ring (m) by force of the closing water underneath.

The sliding bowl bottom is operated hydraulically by means of operating water supplied to the discharge mechanism from an external freshwater line. Opening water is supplied directly to the operating system in the bowl while closing water is supplied to the built-in closing water tank, and pumped to the operating system through the bowl spindle.

The opening and closing only takes a fraction of a second, therefore the discharge volume is limited to a certain percentage of the bowl volume. This action is achieved by the closing water filling space above the upper distributor ring and pushing the sliding bowl bottom upwards. Simultaneously, the water in the chamber below the operating slide is drained off through the nozzles in the bowl body.

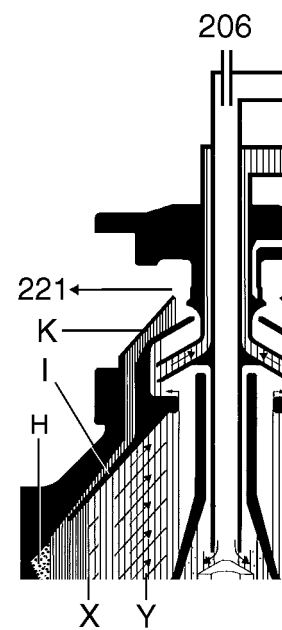

Sludge discharge mechanism

- L Sludge ports
- M Sliding bowl bottom
- m Sealing ring
- N Upper distributor ring
- O Operating slide
- P Lower distributor ring
- R Bowl body

Bowl opening

The key event to start a sludge discharge is the downward movement of the operating slide. This is accomplished by supply of opening water (372) to the discharge mechanism. Water is drained off through nozzles (Y) in the bowl body. The sliding bowl bottom is rapidly pressed downwards by the force from the liquid in the bowl, opening the sludge ports.

Bowl closing

After the sludge is discharged the sliding bowl bottom is immediately pressed up and the sludge ports in the bowl wall are closed.

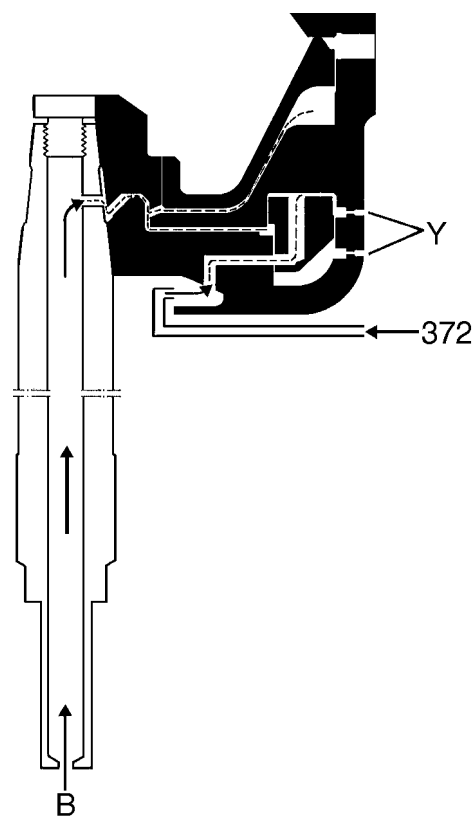

Supply of opening water and closing water

372 Opening water

B Closing and make-up water through bowl spindle

Y Nozzles

2.2.6 Power transmission

Bowl spindle

In addition to its primary role in the power transmission system, the bowl spindle also serves as:

- pump for the closing water
- supply pipe for the closing water
- lubricator for spindle ball bearings.

Closing water is pumped through the hollow spindle (B) to the discharge mechanism in the bowl. For this purpose a pump sleeve (b4) is fitted in the lower end.

The two spindle bearings are lubricated with oil mist. An oil pump (b3) creates the oil mist, which is sucked through the upper ball bearing by a fan (b1). Oil is supplied via an oil filling device, which also serves as a level indicator.

Two identical ring-shaped rubber buffers (b2) support the top bearing housing. The buffers are held in place by a buffer holder and form channels through which the recirculated oil passes.

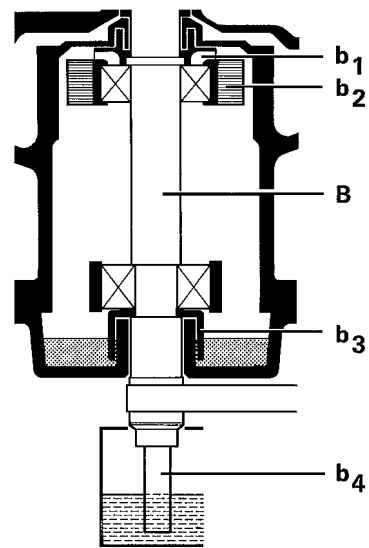

Bowl spindle assembly

- B Bowl spindle
- b1 Fan
- b2 Rubber buffers
- b3 Oil pump
- b4 Sleeve

G0112721

Belt drive

The bowl spindle is driven by a flat belt. Adaptation to 50 or 60 Hz power supply is made by selecting the motor belt pulley with the appropriate diameter. A longer belt is needed for the pulley for 50 Hz.

Correct tension is set by means of a spring-loaded belt tightener.

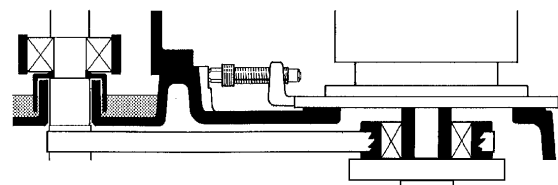

Belt drive

G0112821

Friction coupling

The friction coupling on the motor pulley ensures gentle start-up and prevents overload of the electric motor. Centrifugal force creates a torque that acts on the pulley through the friction elements.

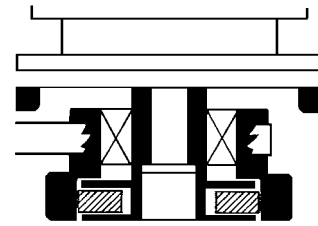

Friction coupling

G0112911

2.2.7 Sensors and indicators**Sight glass**

The sight glass shows the oil level in the oil sump.

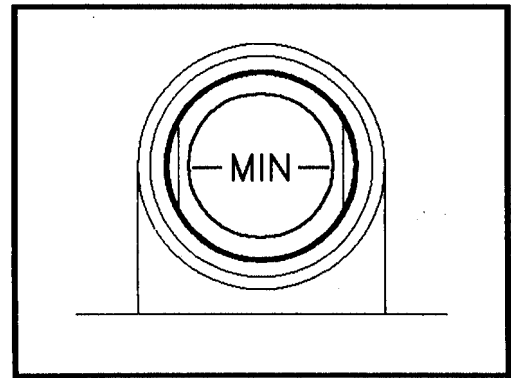

S0009411

Vibration switch (option)

The vibration switch, properly adjusted, trips on a relative increase in vibration.

The vibration switch is sensitive to vibration in a direction perpendicular to its base. It contains a vibration detecting mechanism that actuates a snap-action switch when the selected level of vibration is exceeded. After the switch has tripped it must be reset manually by pressing the button on the switch.

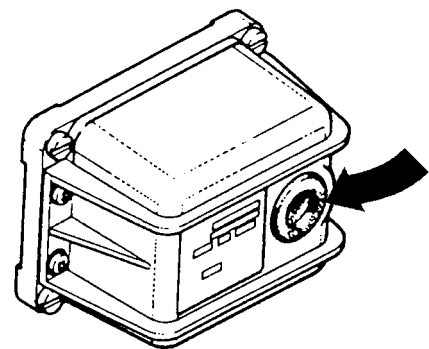

Reset push button on vibration switch

G0548421

2.3 Definitions

Back pressure	Pressure in the separator outlet.
Clarification	Liquid/solids separation with the intention of separating particles, normally solids, from a liquid having a lower density than the particles.
Clarifier disc	An optional disc, which replaces the gravity disc in the separator bowl, in the case of clarifier operation. The disc seals off the heavy phase outlet in the bowl, thus no liquid seal exists.
Counter pressure	See Back pressure.
Density	Mass per volume unit. Expressed in kg/m ³ at a specified temperature, normally at 15 °C.
Gravity disc	Disc in the bowl hood for positioning the interface between the disc stack and the outer edge of the top disc. This disc is only used in purifier mode.
Interface	Boundary layer between the heavy phase (water) and the light phase (oil) in a separator bowl.
Intermediate Service (IS)	Overhaul of separator bowl and inlet/outlet. Renewal of seals in bowl and inlet/outlet.
Major Service (MS)	Overhaul of the complete separator, including bottom part (and activities included in an Intermediate Service). Renewal of seals and bearings in bottom part.
Phase	Light phase: the lighter liquid separated, e.g. oil. Heavy phase: the heavier liquid separated, e.g. water.
Purification	Liquid/liquid/solids separation with the intention of separating two intermixed and mutually insoluble liquid phases of different densities. Solids having a higher density than the liquids can be removed at the same time. The lighter liquid phase, which is the major part of the mixture, shall be purified as far as possible.
Sediment (sludge)	Solids separated from a liquid.
Sludge discharge	Ejection of sludge from the separator bowl.
Throughput	The feed of process liquid to the separator per time unit. Expressed in m ³ /hour or litres/hour.
Viscosity	Fluid resistance against movement. Normally expressed in centistoke (cSt = mm ² /s), at a specified temperature.
Water seal	Water in the solids space of the separator bowl to prevent the light phase (oil) from leaving the bowl through the heavy phase (water) outlet, in purifier mode.

3 Service Instructions

Contents

3.1 Periodic maintenance	28	3.7 Cleaning	53
3.1.1 Introduction	28	3.7.1 Cleaning agents	54
3.1.2 Maintenance intervals	28	3.7.2 Cleaning of bowl discs	55
3.1.3 Maintenance procedure	30	3.8 Oil change	56
3.1.4 Service kits	30	3.8.1 Oil change procedure	56
3.2 Maintenance Logs	31	3.9 Vibration	58
3.2.1 Daily checks	31	3.9.1 Vibration analysis	58
3.2.2 Oil change - monthly	31	3.9.2 Vibration switch (optional)	59
3.2.3 IS - Intermediate Service	32	3.10 General directions	60
3.2.4 MS - Major Service	34	3.10.1 Ball and roller bearings	60
3.3 Check points at Intermediate Service	36	3.10.2 Before shut-downs	63
3.3.1 Corrosion	36		
3.3.2 Erosion	38		
3.3.3 Cracks	39		
3.3.4 Discharge mechanism	40		
3.3.5 Bowl hood and sliding bowl bottom	40		
3.3.6 Spindle top cone and bowl body nave	43		
3.3.7 Threads of inlet pipe, paring disc	43		
3.3.8 Threads on bowl hood and bowl body	44		
3.3.9 Priming of bowl parts	46		
3.3.10 Disc stack pressure	47		
3.4 Check points at Major Service	48		
3.4.1 Paring disc height adjustment	48		
3.4.2 Radial wobble of bowl spindle	50		
3.5 3-year service	51		
3.6 Lifting instructions	52		

3.1 Periodic maintenance

3.1.1 Introduction

Periodic, preventive maintenance reduces the risk of unexpected stoppages and breakdowns. Maintenance logs are shown on the following pages in order to facilitate periodic maintenance.



Disintegration hazards

Separator parts that are worn beyond their safe limits or incorrectly assembled may cause severe damage or fatal injury.

3.1.2 Maintenance intervals

The following directions for periodic maintenance give a brief description of which parts to clean, check and renew at different maintenance intervals.

The service logs for each maintenance interval later in this chapter give detailed enumeration of the checks that must be done.

Daily checks consist of simple check points to carry out for detecting abnormal operating conditions.

Oil change interval is 1500 hours. If the total number of operating hours is less than 1500 hours change oil at least once every year.

Time of operation between oil changes can be extended from the normal 1500 hours to 2000 hours if a synthetic oil of group D is used.

In seasonal operation change the oil before a new period.

IS - Intermediate Service consists of an overhaul of the separator bowl, inlet and outlet every 3 months or 2000 operating hours. Seals in bowl and gaskets in the inlet/outlet device and operating device are renewed.

MS - Major Service consists of an overhaul of the complete separator every 12 months or 8000 operating hours. An Intermediate Service is performed, and the flat belt, friction elements, seals and bearings in the bottom part are renewed.

3-year service consists of service of the coupling bearings, service of frame intermediate part and renewal of frame feet. The rubber feet get harder with increased use and age.

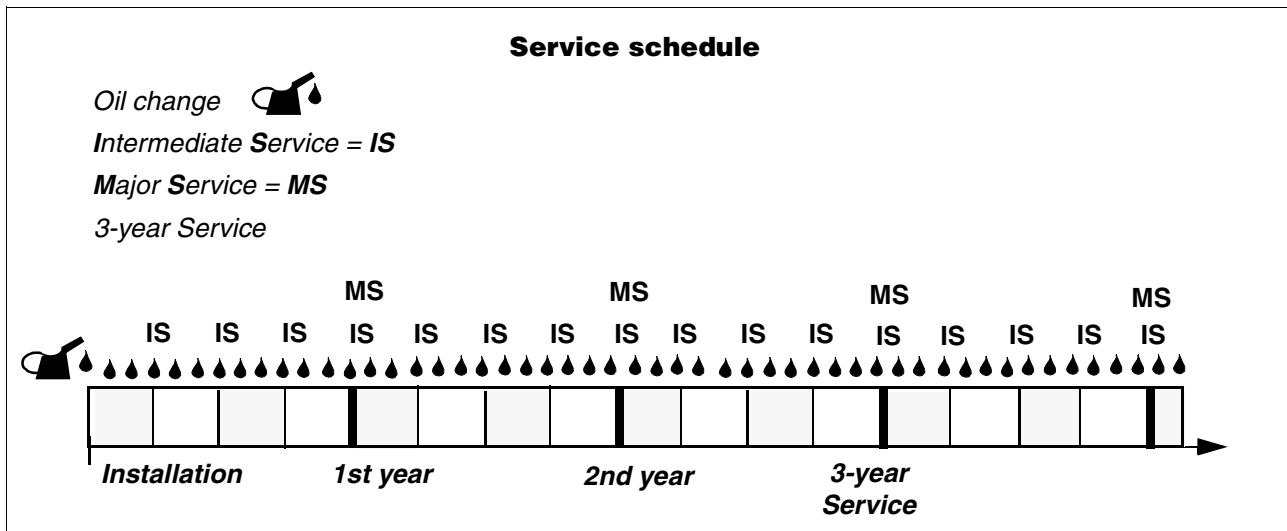

Other

Check and prelubricate spindle bearings of separators which have been out of service for 6 months or longer. See also [3.10.2 Before shut-downs, page 63](#).

NOTE

Do not interchange bowl parts!

To prevent mixing of parts, e.g. in an installation comprising several machines of the same type, the major bowl parts carry the machine manufacturing number or its last three digits.

3.1.3 Maintenance procedure

At each intermediate and major service, take a copy of the service log and use it for notations during the service.

An intermediate and major service should be carried out in the following manner:

- 1** Dismantle the parts as mentioned in the service log and described in chapter [4 Dismantling/Assembly, page 65](#). Place the separator parts on clean, soft surfaces such as pallets.
- 2** Inspect and clean the dismantled separator parts according to the service log.
- 3** Fit all the parts delivered in the service kit while assembling the separator as described in chapter [4 Dismantling/Assembly, page 65](#). The assembly instructions have references to check points which should be carried out during the assembly.

3.1.4 Service kits

Special service kits are available for Intermediate Service (IS), Major Service (MS) and 3-year service (3-YSK).

For other services the spare parts have to be ordered separately.

Note that the parts for IS are **not** included in the MS kit.

The contents of the service kits are described in the *Spare Parts Catalogue*.

NOTE

Always use Alfa Laval genuine parts as otherwise the warranty will become invalid. Alfa Laval takes no responsibility for the safe operation of the equipment if non-genuine spare parts are used.

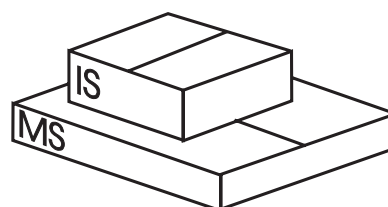

Spare parts kits are available for Intermediate Service and Major Service

3.2 Maintenance Logs

3.2.1 Daily checks

The following steps should be carried out daily.

Main component and activity	Part	Page	Notes
Inlet and outlet			
Check for leakage	Connecting housing	-	
Separator bowl			
Check for vibration and noise		-	
Belt transmission			
Check for vibration and noise		-	
Oil sump			
Check	Oil level	-	
Electrical motor			
Check for vibration, heat and noise See manufacturer's instructions			

3.2.2 Oil change - monthly

The oil change and check of belt transmission should be carried out every 1500 hours of operation.

When using a group D oil, time of operation between oil changes can be extended from the normal 1500 hours to 2000 hours.

When the separator is run for short periods, the lubricating oil must be changed every 12 months even if the total number of operating hours is less than 1500 hours (less than 2000 hours if a group D oil is used).

See chapter [5.7 Lubricants, page 133](#) for further information on oil brands etc.

Main component and activity	Part	Page	Notes
Bowl spindle and transmission			
Check	Belt tension	<i>107</i>	
Change	Oil in oil sump	<i>56</i>	

3.2.3 IS - Intermediate Service

Name of plant:

Local identification:

Separator: P 605

Manufacture No./Year:

Total running hours:

Product No.: 881099-06-02/0

Date:

Signature:

Renew all parts included in the Intermediate Service kit (IS) and do the following activities.

Main component and activity	Part	Page	Notes
Inlet and outlet, frame			
Clean and inspect	Threads of inlet pipe	43	
	Paring disc	43	
	Housings and frame hood	-	
Separator bowl			
Clean and inspect	Bowl hood	44	
	Top disc	55	
	Bowl discs	55	
	Distributor	-	
	Nozzles in bowl body	40	
	Sliding bowl bottom	40	
	Discharge mechanism	40	
	Threads on bowl hood and bowl body	44	
	Bowl spindle cone and bowl body nave	43	
Check	Disc stack pressure	47	
	Galling of guide surface	44	
	Corrosion, erosion, cracks	36 - 38	
Power transmission			
Check	Belt and belt tension	107	
Change	Oil in oil sump	56	
Electrical motor			
Lubrication (if nipples are fitted)	See sign on motor	-	

Main component and activity	Part	Page	Notes
Signs and labels on separator			
Check attachment and legibility	Safety label on hood	144	
	Other plates and labels	144	

3.2.4 MS - Major Service

Name of plant: _____ Local identification: _____
 Separator: P 605 Manufacture No./Year: _____
 Total running hours: _____ Product No.: 881099-06-02/0
 Date: _____ Signature: _____

Renew all parts included in the Intermediate and Major Service kits and do the following activities.

Main component and activity	Part	Page	Notes
Inlet and outlet, frame			
Clean and inspect	Threads of inlet pipe	43	
	Paring disc	43	
	Housings and frame hood	-	
Separator bowl			
Clean and inspect	Bowl hood	44	
	Top disc	55	
	Bowl discs	55	
	Distributor	-	
	Nozzles in bowl body	40	
	Sliding bowl bottom	40	
	Discharge mechanism	40	
	Threads on bowl hood and bowl body	44	
	Bowl spindle cone and bowl body nave	43	
Check	Height of paring disc	48	
	Disc stack pressure	47	
	Galling of guide surface	44	
	Corrosion, erosion, cracks	36 - 38	

Main component and activity	Part	Page	Notes
Vertical driving device			
Clean and inspect	Oil mist fan	89	
	Oil pump	89	
	Water tank	113	
	Pump sleeve		
	Bowl spindle	86	
	Ball bearing housing indentations	86	
Check	Radial wobble of bowl spindle	50	
Oil sump			
Clean	Oil sump	56	
Change	Oil	56	
Clean and inspect	Oil filling device	112	
Friction coupling			
Clean and inspect	Friction coupling	103	
Electrical motor			
Replace	Bearings ¹⁾		
Signs and labels on separator			
Check attachment and legibility	Safety label on hood	144	
	Other signs and labels	144	

¹⁾ See manufacturer's instructions.

3.3 Check points at Intermediate Service

3.3.1 Corrosion

Evidence of corrosion attacks should be looked for and rectified each time the separator is dismantled. Main bowl parts such as the bowl body and hood must be inspected with particular care for corrosion damage.



Disintegration hazard

Inspect regularly for corrosion damage. Inspect frequently if the process liquid is corrosive.

Always contact your Alfa Laval representative if you suspect that the largest depth of a corrosion damage exceeds 1,0 mm or if cracks have been found. Do not continue to use the separator until it has been inspected and given clearance for operation by Alfa Laval.

Cracks or damage forming a line should be considered as being particularly hazardous.

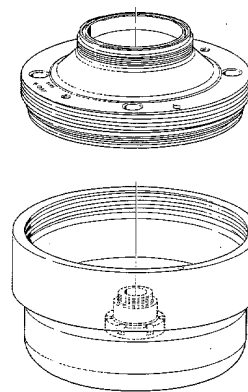

Main bowl parts to check for corrosion

G0172111

Non-stainless steel and cast iron parts

Corrosion (rusting) can occur on unprotected surfaces of non-stainless steel and cast iron. Frame parts can corrode when exposed to an aggressive environment.

Stainless steel

Stainless steel parts corrode when in contact with either chlorides or acidic solutions. Acidic solutions cause a general corrosion. The chloride corrosion is characterised by local damage such as pitting, grooves or cracks. The risk of chloride corrosion is higher if the surface is

- exposed to a stationary solution,
- in a crevice,
- covered by deposits,
- exposed to a solution that has a low pH value.

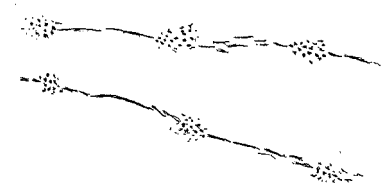

Example of chloride corrosion in stainless steel.

A corrosion damage caused by chlorides on stainless steel begins as small dark spots that can be difficult to detect.

- Inspect closely for all types of damage by corrosion and record these observations carefully.
- Polish dark-coloured spots and other corrosion marks with a fine grain emery cloth. This may prevent further damage.



Polish corrosion marks to prevent further damage.



Disintegration hazard

Pits and spots forming a line may indicate cracks beneath the surface.

All forms of cracks are a potential danger and are totally unacceptable.

Replace the part if corrosion can be suspected of affecting its strength or function.

Other metal parts

Separator parts made of materials other than steel, such as brass or other copper alloys, can also be damaged by corrosion when exposed to an aggressive environment. Possible corrosion damage can be in the form of pits and/or cracks.

3.3.2 Erosion

Erosion can occur when particles suspended in the process liquid slide along or strike against a surface. Erosion can become intensified locally by flows of higher velocity.



Disintegration hazard

Inspect regularly for erosion damage. Inspect frequently if the process liquid is erosive.

Always contact your Alfa Laval representative if the largest depth of any erosion damage exceeds 1,0 mm. Valuable information as to the nature of the damage can be recorded using photographs, plaster impressions or hammered-in lead.

Erosion is characterised by:

- Burnished traces in the material.
- Dents and pits having a granular and shiny surface.

Parts of the bowl particularly subjected to erosion are:

- The paring disc.
- The top disc.
- The underside of the distributor in the vicinity of the distribution holes and wings.
- The sludge ports.

Look carefully for any signs of erosion damage. Erosion damage can deepen rapidly and consequently weaken parts by reducing the thickness of the metal.

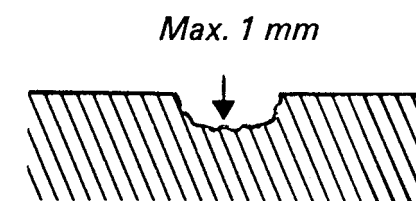

Maximum permitted erosion.

3.3.3 Cracks

Cracks can initiate on the machine after a period of operation and propagate with time.

- Cracks often initiate in areas exposed to high cyclic material stresses. These cracks are called fatigue cracks.
- Cracks can also initiate due to corrosion in an aggressive environment.
- Although very unlikely, cracks may also occur due to the low temperature embrittlement of certain materials.

The combination of an aggressive environment and cyclic stresses will speed-up the formation of cracks. Keeping the machine and its parts clean and free from deposits will help to prevent corrosion attacks.



Disintegration hazard

All forms of cracks are potentially dangerous as they reduce the strength and functional ability of components.

Always replace a part if cracks are present

It is particularly important to inspect for cracks in rotating parts.

Always contact your Alfa Laval representative if you suspect that the largest depth of the damage exceeds 1,0 mm. Do not continue to use the separator until it has been inspected and cleared for operation by Alfa Laval.

3.3.4 Discharge mechanism

Dirt and lime deposits in the sludge discharge mechanism can cause discharge malfunction or no discharge.

- Thoroughly clean and inspect the parts. Pay special attention to important surfaces (1, 2, 3 and 4). If necessary, polish with steel wool.
- Clean nozzles (5) using soft iron wire or similar. Note that lime deposits can with advantage be dissolved in a 10% acetic acid solution.

Use Loctite 242 on the threads if the nozzles have been removed or replaced.

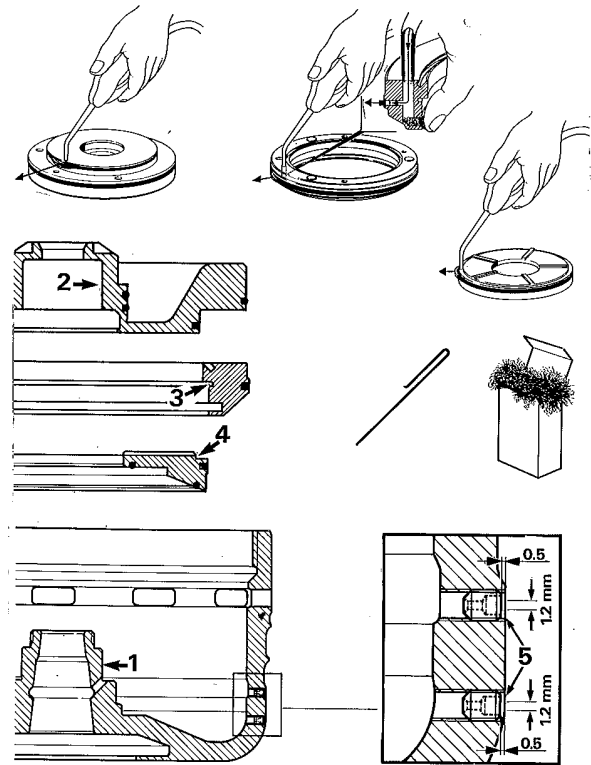

G0121511

3.3.5 Bowl hood and sliding bowl bottom

Poor sealing between the bowl hood seal ring and the edge of the sliding bowl bottom will cause a leakage of process liquid from the bowl.

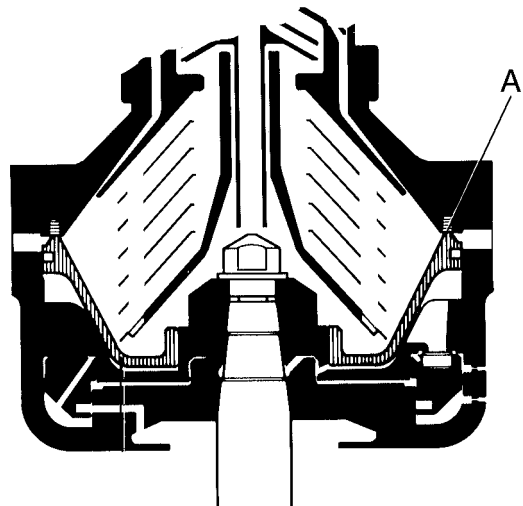

A Sealing surface in the bowl between bowl hood and sliding bowl bottom.

G0071031

Fit a new bowl hood seal ring at each Intermediate Service (IS) if the old ring is damaged or indented more than 0,5 mm.

Fit a new ring as follows:
Press the ring into the groove with a straight board (1" x 4"), placed across the ring.

NOTE

If a new ring is too narrow, put it into hot water, 70 - 80 °C for about 5 minutes.

If it is too wide it will recover after drying at 80 - 90 °C for about 24 hours.

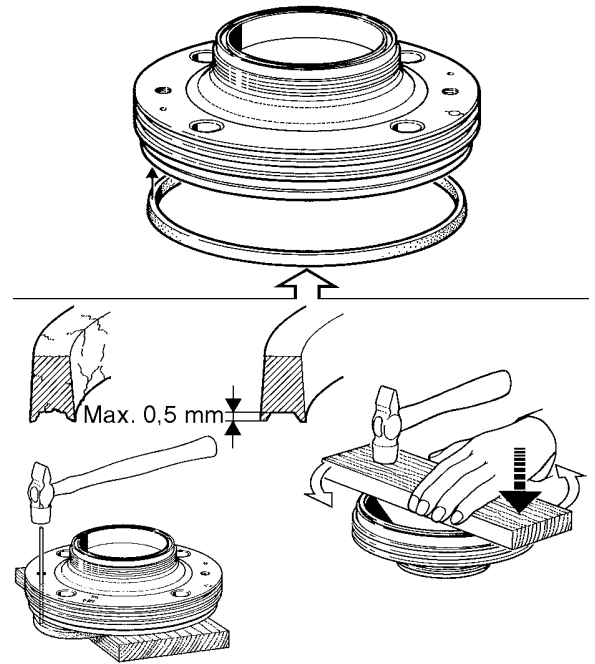

Exchange of seal ring in bowl hood.

Check the sealing edge (a) of the sliding bowl bottom.

If damaged through corrosion or erosion or in other ways it can be rectified by turning in a lathe. Minimum permissible height of sealing edge: 4,5 mm.

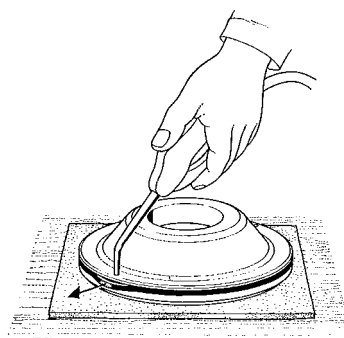
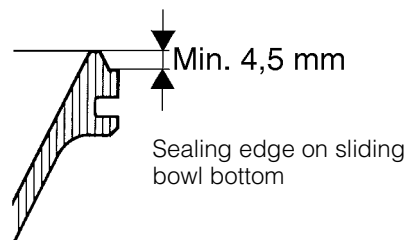
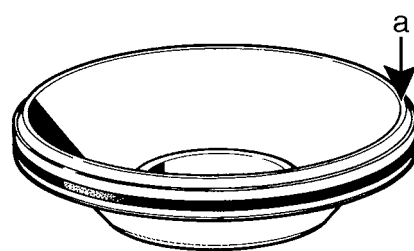

Removal of seal ring on sliding bowl bottom.

G0071221

G0071231

3.3.6 Spindle top cone and bowl body nave

Impact marks on the spindle cone or in the bowl body nave may cause the separator to vibrate while running.

Corrosion may cause the bowl to stick firmly to the spindle cone and cause difficulties during the next dismantling.

- Remove any impact marks using a scraper and/or a whetstone.
Rust can be removed by using a fine-grain emery cloth (e.g. No. 320). Finish with polishing paper (e.g. No. 600).

NOTE

Always use a scraper with great care. The conicity must not be marred.

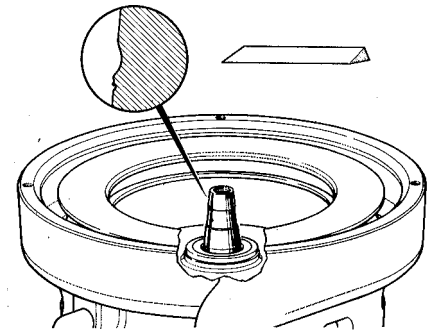
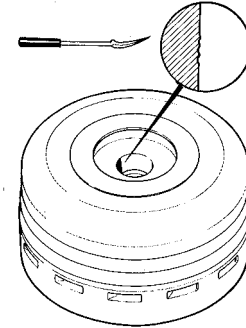

Use whetstone or scraper with great care

G0071611

3.3.7 Threads of inlet pipe, paring disc

Damage to threads or a broken paring disc can prevent correct tightening of the inlet pipe and cause the paring disc to scrape against the top disc, even though the height adjustment of the paring disc has been made correctly.

- Examine the threads for damage and rectify if required.
- Examine the paring disc for damage and to see if the disc walls have parted. If they have, the inlet pipe has to be replaced with a new one.

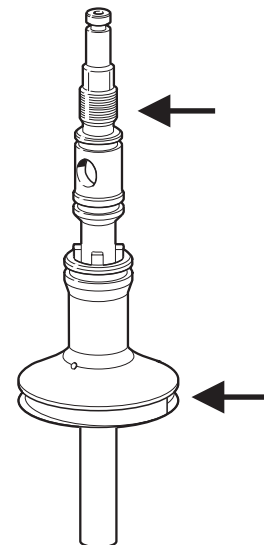

G0113031

3.3.8 Threads on bowl hood and bowl body

Excessive wear or impact marks on threads and guide surfaces of the bowl hood or bowl body can cause seizure damage.

Examine the thread condition by tightening the bowl hood after removing the disc stack and top disc from the bowl.

When the bowl is new the alignment marks on the bowl hood and the bowl body should be aligned. If not, contact an Alfa Laval representative.

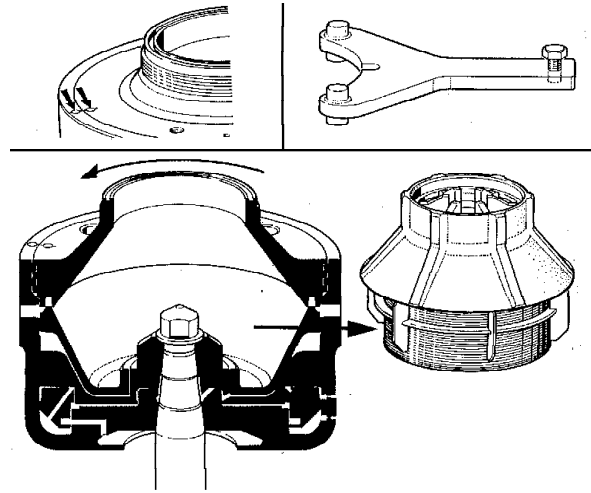

G0071311

Wear

If thread wear is observed, mark the bowl body at the new position by punching a new alignment mark. If the mark on the bowl hood passes the mark on the bowl body by more than 25°, (A in the illustration) an Alfa Laval representative should be contacted immediately.

The measure A in millimetres (mm) is obtained by calculating bowl outside diameter D times 0,2.

If the marks are illegible, an Alfa Laval representative should be contacted for determination and punching of new alignment marks.

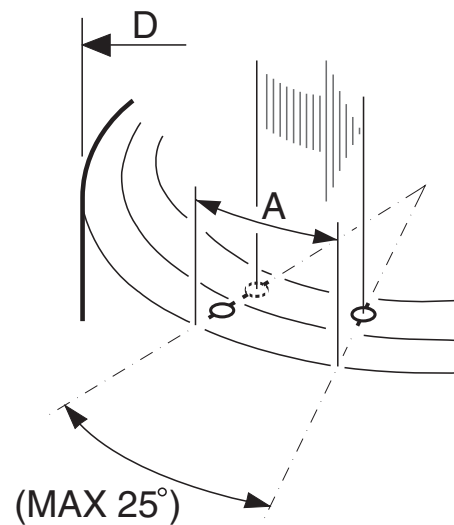

G0578111



Disintegration hazards

Wear on threads must not exceed safety limit. f mark on bowl hood must not pass f mark on bowl body by more than 25°.

Damage

The position of threads, contact and guide surfaces are indicated by arrows in the illustration.

Examine for burrs and protrusions caused by impact.

Clean the threads, contact and guide surfaces with a suitable degreasing agent.

**Cut hazard**

The threads have sharp edges which can cause cuts.

If damage is found, rectify by using a whetstone or fine emery cloth. Recommended grain size: 240.

If the damage is bad, use a fine single-cut file, followed by a whetstone. After rectifying, the threads have to be primed with Molykote 1000.

Contact surfaces to inspect on the bowl

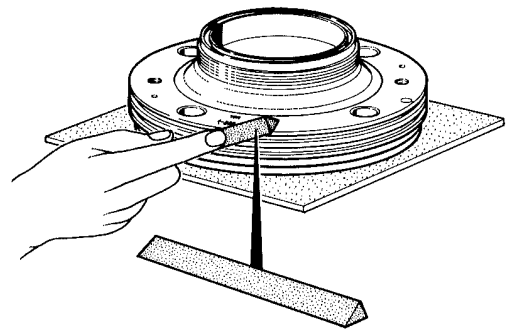
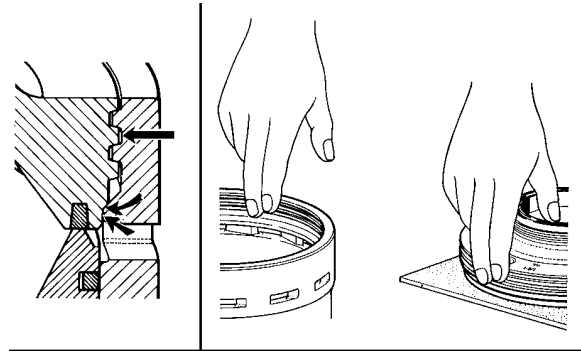

3.3.9 Priming of bowl parts

The instruction refers to contact surfaces (dark shaded) of both matching parts.

Before assembly:

- 1** These surfaces should be sprayed with Molykote D321R after a careful cleaning.
- 2** Air cure for 15 minutes.
- 3** Polish to an even, homogenous surface.
- 4** Spray a second time.
- 5** Air cure for 15 minutes.
- 6** Polish to a shiny surface, the surface should look like well polished leather when properly done.
- 7** Finish the treatment by lubricating the surfaces with lubricating paste see [5.7.3 Recommended lubricants, page 135](#).

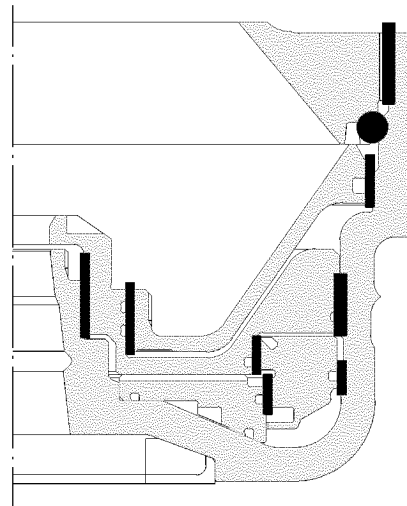

G0887731

3.3.10 Disc stack pressure

The bowl hood exerts a pressure on the disc stack clamping it in place.

NOTE

Insufficient pressure in the disc stack may affect the bowl balance, which in turn will cause abnormal vibration of the separator and shorten the life of ball bearings.

- 1** Place the bowl hood on the top of the disc stack and tighten it by hand. The assembly mark on the bowl hood should now be positioned at the angle a (see illustration), $30^\circ - 60^\circ$ ahead of the corresponding mark on the bowl body.
- 2** If the bowl hood can be tightened by hand without resistance until the marks are in line with each other, an extra disc must be added to the top of the disc stack beneath the top disc.

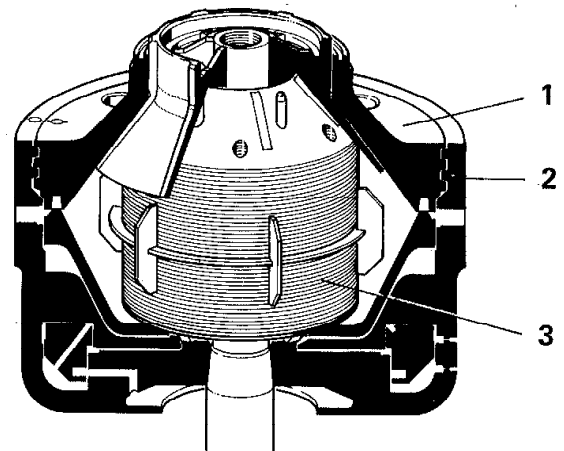

- 1 Bowl hood
- 2 Bowl body
- 3 Disc stack. Number of discs
 - below wing insert: 42
 - above wing insert: at least 41

- 3** If one or more discs have been added re-check the disc stack pressure by repeating the procedure above.

NOTE

The top disc can stick inside the bowl hood and fall when the hood is lifted.

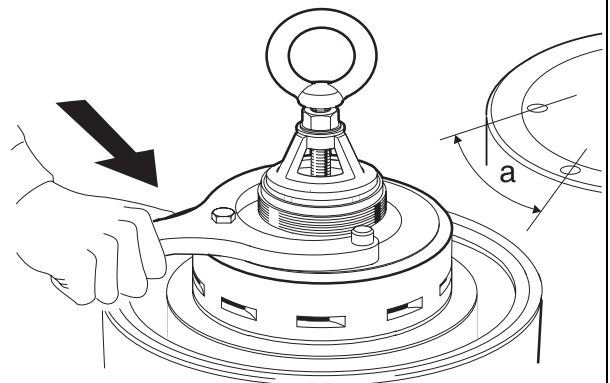

- a Angle $30^\circ - 60^\circ$ between assembly marks before final tightening

3.4 Check points at Major Service

3.4.1 Paring disc height adjustment

The height of the paring disc above the frame hood must be measured if the bowl spindle has been dismantled or if the bowl has been replaced with a new one.

NOTE

Incorrect height position can cause the paring disc (14) to scrape against the paring chamber cover.

Pay attention to scraping noise at start-up after service.

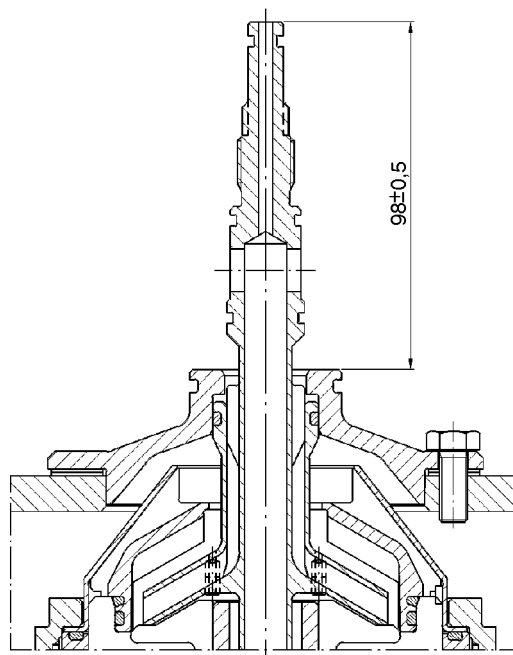

G0883911

- 1** Assemble the bowl and frame hood as described in chapter 4.1.2 Inlet/outlet and bowl - assembly, page 76.
- 2** Measure the distance according to the illustration above. Adjust the distance by adding or removing height adjusting rings (7).
- 3** Fit the support ring (5) and the inlet/outlet housing. Tighten the nut with 30 Nm.

Left-hand thread!

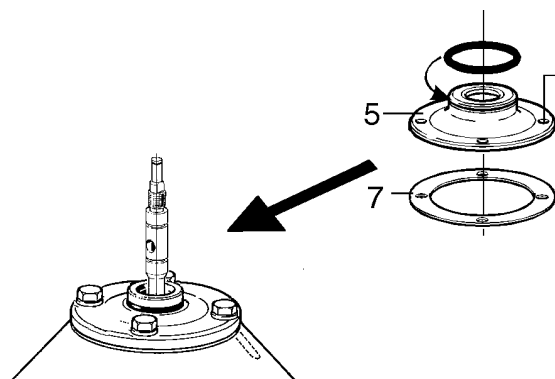

G00729A1

- 4** Rotate the bowl spindle by hand by means of the flat belt. If it does not rotate freely or if a scraping noise is heard, incorrect height adjustment or incorrect fitting of the inlet pipe can be the cause. Remove the parts and readjust.
- 5** Finally, fit the safety device.

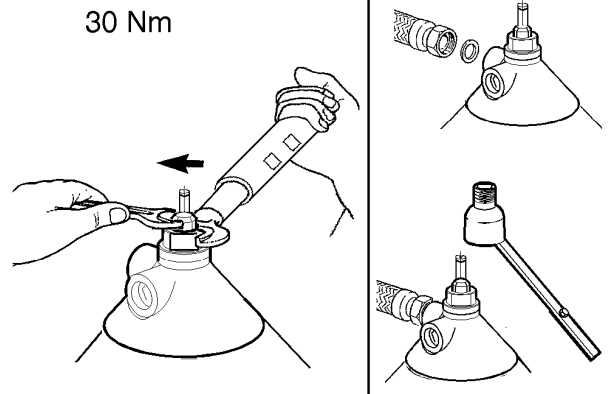

3.4.2 Radial wobble of bowl spindle

The bowl spindle wobble must be measured if the bowl spindle has been dismantled or if rough bowl run (vibration) occurs.

NOTE

Spindle wobble will cause rough bowl run. This leads to vibration and reduces lifetime of ball bearings.

Check the wobble **before** removing the bowl spindle.

If the bowl spindle has been dismantled check the wobble before installing the bowl.

- 1 Fit a dial indicator in a support and fasten it in position as illustrated.
- 2 Remove the water tank from the frame bottom part for access to the flat belt. Use the flat belt to turn the spindle.
- 3 Permissible radial wobble: max. 0,04 mm.

If the spindle wobble is more than the maximum permitted value, contact Alfa Laval representatives.

- 4 Finally fit the water tank to the frame bottom part.

Incorrect belt tension causes displacement of the vertical line of the spindle centre, but does not affect the wobble of the spindle.

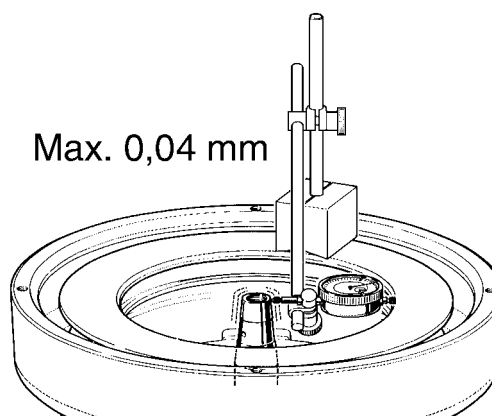

3.5 3-year service

Exchange of frame feet

See [4.8.1 Mounting of new frame feet](#), page 115.

Friction coupling

Exchange of ball bearings, see [4.3 Friction coupling](#), page 100.

Frame intermediate part

Replace O-ring and gasket, see [4.2.2 Bowl spindle and frame - assembly](#), page 92.

3.6 Lifting instructions

- 1 Remove the inlet/outlet housings, the frame hood and the bowl according to the instructions in chapter 4.1.1 Inlet/outlet and bowl - dismantling, page 71.

NOTE

Make sure to remove the cap nut fixing the bowl to the bowl spindle.

Before lifting the bowl, check that the bowl hood has been screwed home into the bowl body. Less than 2 mm of bowl hood threading must remain above the bowl body edge. See illustration.

When lifting the bowl, use the compression tool fastened on the distributor.

- 2 Disconnect the motor cables.
- 3 Tighten the frame hood.
- 4 Fit the lifting eyes. The two eyebolts must be fitted in the holes nearest to the electric motor.
- 5 Use two endless slings to lift the separator. Length of each sling: minimum 1,5 metres. Thread the slings through the lifting eyes and fit them to the hook of the hoist.
- 6 Unscrew the foundation bolts.
- 7 When lifting and moving the separator, obey normal safety precautions for lifting large heavy objects.

Do not lift the separator unless the bowl has been removed.

- 8 Remove the lifting eyes afterwards.

WARNING

Crush hazards

Use only the two special lifting eyes (M12) for lifting the machine. They are to be screwed into the special threaded holes.

Other holes are not dimensioned for lifting the machine.

A falling separator can cause accidents resulting in serious injury and damage.

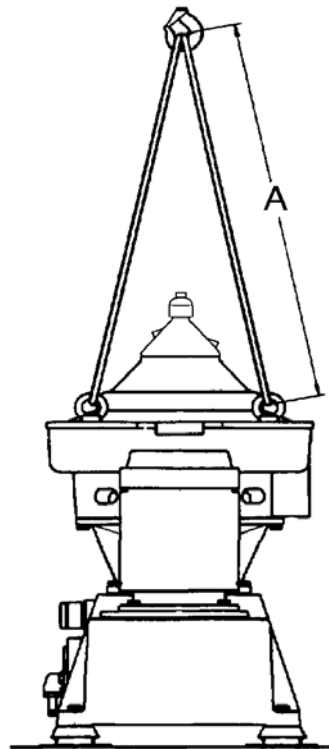
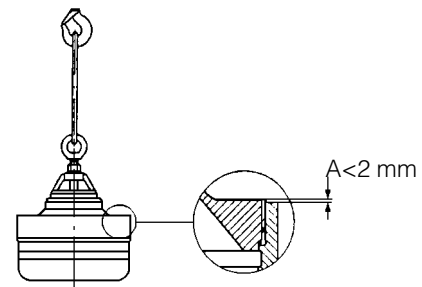

- A Minimum 750 mm distance between lifting eye and hook.
Use a lifting hook with catch.

NOTE

Separator without bowl: Use lifting slings for WLL 300 kg.

Bowl: Use lifting slings for WLL 100 kg.

3.7 Cleaning

External cleaning

The external cleaning of frame and motor should be restricted to brushing, sponging or wiping while the motor is running or is still hot.

Never wash down a separator with a direct water stream. Totally enclosed motors can be damaged by direct hosing to the same extent as open motors and even more than those, because:

- Many operators believe that these motors are sealed, and normally they are not.
- A water jet played on these motors will produce an internal vacuum, which will suck the water between the metal-to-metal contact surfaces into the windings, and this water cannot escape.
- Water directed on a hot motor may cause condensation resulting in short-circuiting and internal corrosion.

Be careful even when the motor is equipped with a protecting hood. Never play a water jet on the ventilation grill of the hood.

Use a brush and a sponge or cloth when cleaning.

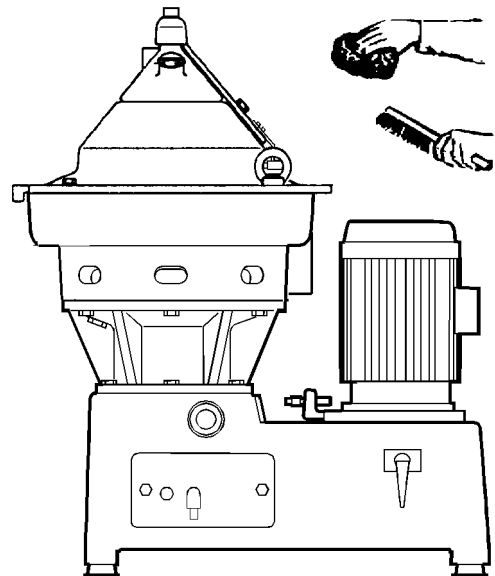

Never wash down a separator with a direct water stream or spray.

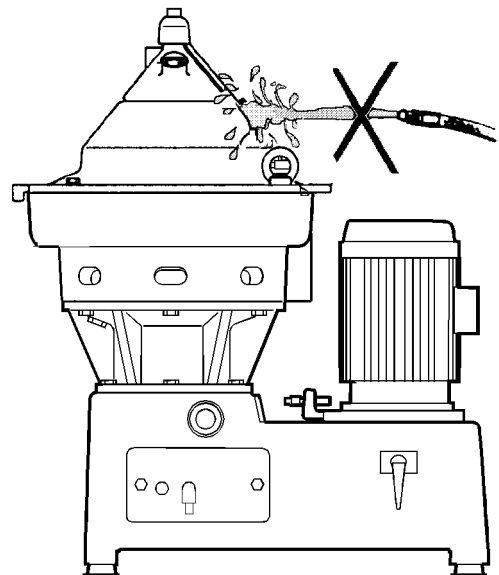

3.7.1 Cleaning agents

When using chemical cleaning agents, make sure you follow the general rules and suppliers' recommendations regarding ventilation, protection of personnel, etc.

For separator bowl, inlet and outlet

A chemical cleaning agent must dissolve the deposits quickly without attacking the material of the separator parts.

- For cleaning of lube oil separators the most important function of the cleaning agent is to be a good solvent for the gypsum in the sludge. It should also act as a dispersant and emulsifier for oil. It is recommended to use Alfa Laval cleaning liquid for lube oil separators which has the above mentioned qualities. Note that carbon steel parts can be damaged by the cleaning agent if submerged for a long time.
- Fuel oil sludge mainly consists of complex organic substances such as asphaltenes. The most important property of a cleaning liquid for the removal of fuel oil sludge is the ability to dissolve these asphaltenes.

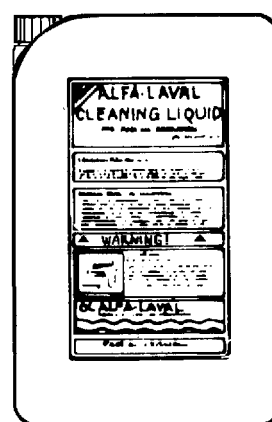

Alfa Laval cleaning liquid for lube oil and fuel oil separators.



Skin irritation hazard

Read the instructions on the label of the plastic container before using the cleaning liquid.

Always wear safety goggles, gloves and protective clothing as the liquid is alkaline and dangerous to skin and eyes.

For parts of the driving devices

Use white spirit, cleaning-grade kerosene or diesel oil.

Oiling (protect surfaces against corrosion)

Protect cleaned carbon steel parts against corrosion by oiling. Separator parts that are not assembled after cleaning must be wiped and coated with a thin layer of clean oil and protected from dust and dirt.

3.7.2 Cleaning of bowl discs**Bowl discs**

Handle the bowl discs carefully so as to avoid damage to the surfaces during cleaning.

NOTE

Mechanical cleaning is likely to scratch the disc surfaces causing deposits to form quicker and adhere more firmly.

A mild chemical cleaning is therefore preferable to mechanical cleaning.

- 1** Remove the bowl discs from the distributor and lay them down, one by one, in the cleaning agent.
- 2** Let the discs remain in the cleaning agent until the deposits have been dissolved. This will normally take between two and four hours.

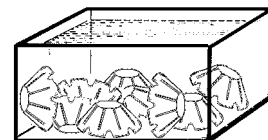

Put the discs one by one into the cleaning agent.

- 3** Finally clean the discs with a soft brush.

**Cut hazards**

The discs have sharp edges that can cause cuts.



Clean the discs with a soft brush.

3.8 Oil change

3.8.1 Oil change procedure

NOTE

Before adding or renewing lubricating oil in the oil sump, the information concerning different oil groups, handling of oils, oil change intervals etc. given in chapter 5.7 Lubricants, page 133 must be well known.

The separator should be level and at standstill when oil is filled or the oil level is checked. The MIN-line on the sight glass refers to the oil level at standstill.

- 1 Place a collecting vessel under the drain hole.
- 2 Pull out (A) the oil filling device and turn it half a turn (B).

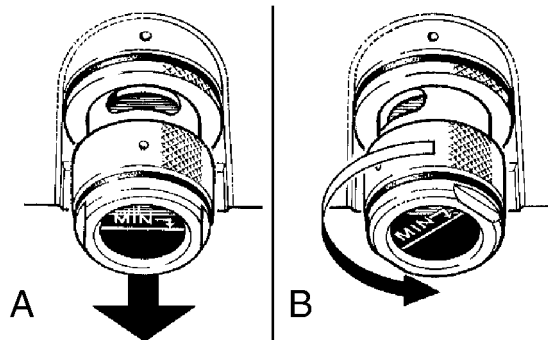

G0068911

- 3 Collect the oil in the vessel.



Burn hazards

The lubricating oil and various machine surfaces can be sufficiently hot to cause burns.

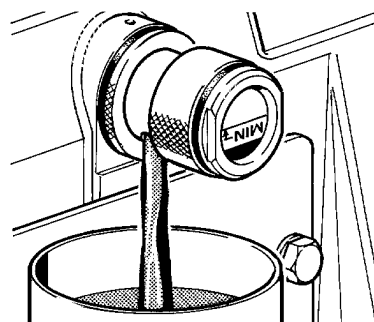

G0173811

- 4** Turn the oil filling device back to its normal position (A), the drain hole pointing upwards.

NOTE

When changing from one group of oil to another, the frame housing and the spindle parts must be thoroughly cleaned before the new oil is filled.

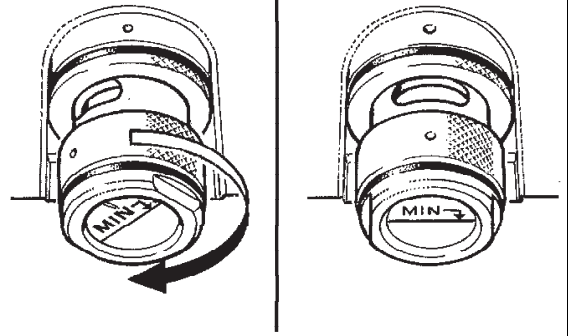

- 5** Fill the oil sump in the frame housing with new oil. The oil level should be slightly above middle of the sight glass. Information on volume see [5.2 Technical data, page 119](#).
- 6** Push in the oil filling device.

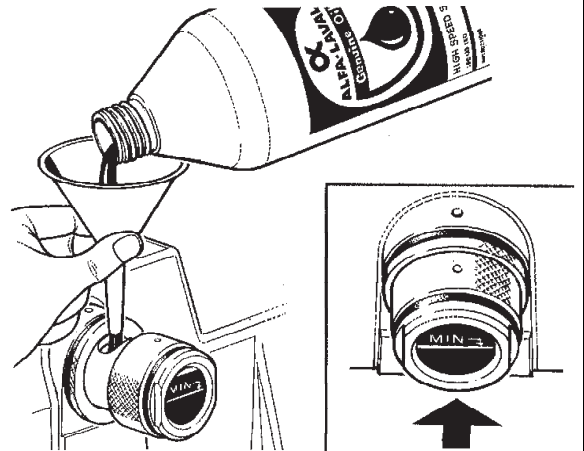

3.9 Vibration

3.9.1 Vibration analysis

A separator normally vibrates and produces a different sound when passing through its critical speeds during run-up and run-down.

It also vibrates and sounds to some extent when running. It is good practice to be acquainted with these normal conditions.

Excessive vibrations and noise indicate that something is wrong. Stop the separator and identify the cause.

Use vibration analysis equipment to periodically check and record the level of vibration.

The level of vibration of the separator should not exceed 9 mm/s.



Disintegration hazards

When excessive vibration occurs, keep bowl filled and stop separator.

The cause of the vibration must be identified and corrected before the separator is restarted.

Excessive vibration can be due to incorrect assembly or poor cleaning of the bowl.

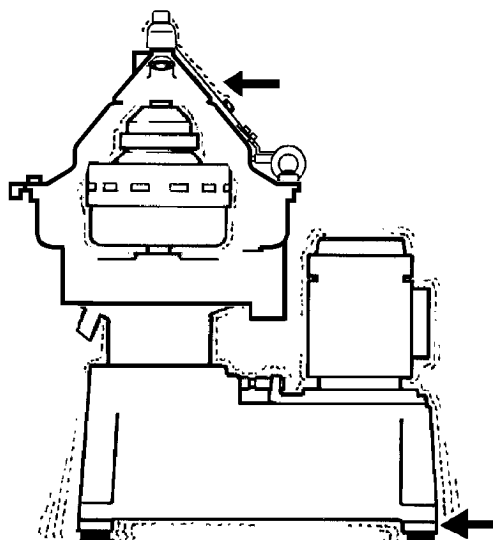

3.9.2 Vibration switch (optional)

Adjustment of setpoint

The vibration switch is adjusted with the separator in operation. The cover must be removed to gain access to the setpoint adjusting screw (1).

- 1** Back-off the setpoint adjusting screw counter-clockwise (A) two or three turns. Press the reset button. If the armature does not remain in the reset position, turn the adjusting screw another turn or two until the armature stays in position when the reset button is pressed.
- 2** Now turn the adjusting screw slowly clockwise until the armature rocks. Mark this position with a line immediately in front-of the adjusting screw pointer (2).
- 3** Back-off the adjusting screw counter-clockwise a three-quarter turn. Press the reset button. If the armature now rocks, turn the adjusting screw counter-clockwise another quarter turn and so on until the armature remains in the reset position.

Refit the cap and fasten with the screws.

NOTE

Further adjustment may become necessary if alarm occurs due to vibration from surrounding equipment.

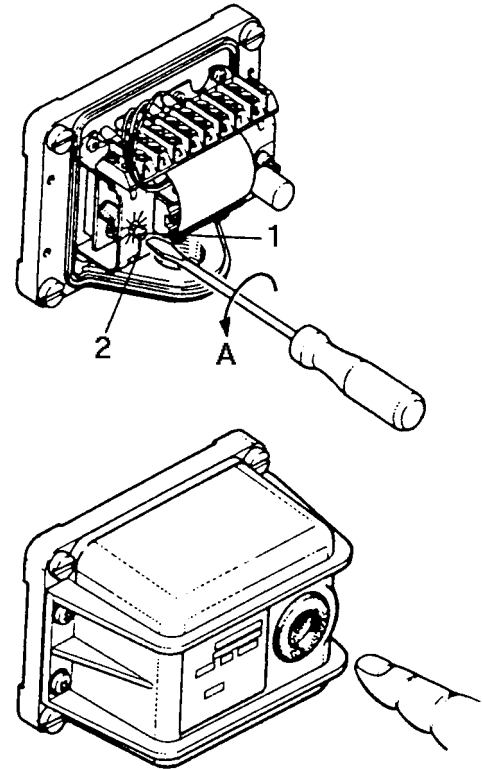

Setpoint adjustment

1. Adjusting screw
2. Pointer
- A. Direction of increased checkpoint (admit higher vibration)

3.10 General directions

3.10.1 Ball and roller bearings

Specially designed bearings for the bowl spindle

The bearings used for the bowl spindle are special to withstand the speed, vibration, temperature and load characteristics of high-speed separators.

Only Alfa Laval genuine spare parts should be used.

A bearing that in appearance looks equivalent to the correct may be considerably different in various respects: inside clearances, design and tolerances of the cage and races as well as material and heat treatment.

NOTE

Using an incorrect bearing can cause a serious breakdown with injury to personnel and damage to equipment as a result.

Do not re-fit a used bearing.
Always replace it with a new one.

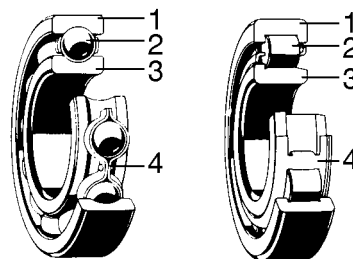

1. Outer race
2. Ball/roller
3. Inner race
4. Cage

G0587321

Dismantling

Remove the bearing from its seat by using a puller. If possible, let the puller engage the inner ring, then remove the bearing with a steady force until the bearing bore completely clears the entire length of the cylindrical seat.

The puller should be accurately centered during dismantling; otherwise it is easy to damage the seating.

NOTE

Do not hit with a hammer directly on the bearing.

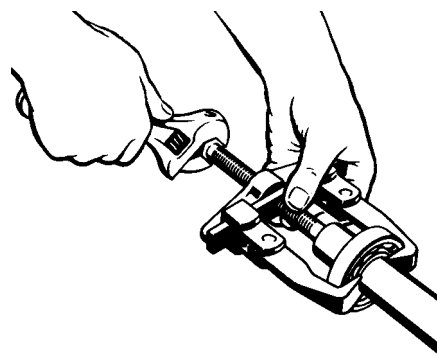

For bearings where no driving-off sleeve is included in the tool kit, use a puller when removing bearings.

G0587411

Cleaning and inspection

Check shaft (spindle) end and/or bearing seat in the housing for damage indicating that the bearing has rotated on the shaft (spindle) and/or in the housing respectively. Replace the damaged part, if the faults cannot be remedied by polishing or in some other way.

Assembly

- Leave new bearings in original wrapping until ready to fit. The anti-rust agent protecting a new bearing should not be removed before use.
- Use the greatest cleanliness when handling the bearings.

To facilitate assembly and also reduce the risk of damage, first clean and then lightly smear the bearing seating on shaft (spindle) or alternatively in housing, with a thin oil.

Clean and smear the bearing seating before assembly.

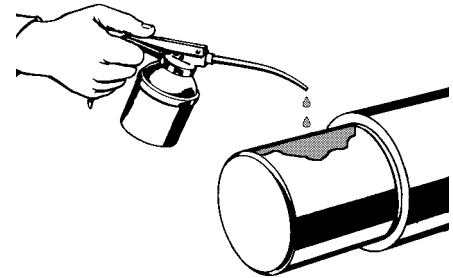

- When assembling ball bearings, the bearings must be heated in oil to maximum 125 °C.

NOTE

Heat the bearing in a clean container with a cover.

Use only clean oil with a flash point above 250 °C.

The bearing must be well covered by the oil and not be in direct contact with the sides or the bottom of the container. Place the bearing on some kind of support or suspended in the oil bath.

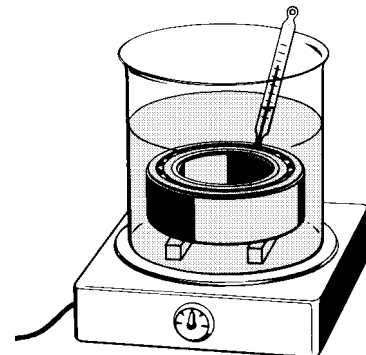

The bearing must not be in direct contact with the container.

- There are several basic rules for assembling cylindrical bore bearings:
 - Never directly strike a bearing's rings, cage or rolling elements while assembling. A ring may crack or metal fragments break off.
 - Never apply pressure to one ring in order to assemble the other.
 - Use an ordinary hammer. Hammers with soft metal heads are unsuitable as fragments of the metal may break off and enter the bearing.
 - Make sure the bearing is assembled at a right angle to the shaft (spindle).
- If necessary use a driving-on sleeve that abuts the ring which is to be assembled with an interference fit, otherwise there is a risk that the rolling elements and raceways may be damaged and premature failure may follow.

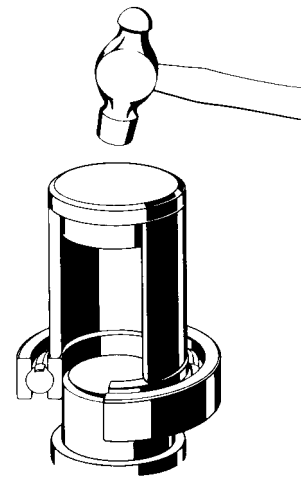

Use a driving-on sleeve for bearings that are not heated.

G0587711

Angular contact ball bearings

Always fit single-row angular contact ball bearings with the wide shoulder of the inner race facing the axial load (upwards on a bowl spindle).

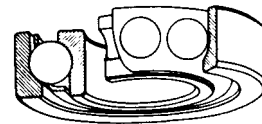

The wide shoulder of the inner race must face the axial load.

G0587211

3.10.2 Before shut-downs

Before the separator is shut-down for a period of time, the following must be carried out:

- Remove the bowl, according to instructions in chapter 4 **Dismantling/Assembly**, page 65.
- Protect parts in contact with process liquid from corrosion by applying a thin layer of oil.
- Remove the O-rings.

Protect cleaned carbon steel parts against corrosion by oiling. Separator parts that are not assembled after cleaning must be wiped and protected against dust and dirt.

NOTE

The bowl must not be left on the spindle during standstill for more than one week.

Vibration in foundations can be transmitted to the bowl and produce one-sided loading of the bearings.

The resultant indentations in the ball bearing races can cause premature bearing failure.

If the separator has been shut-down for more than 3 months but less than 12 months, an Intermediate Service (IS) has to be made before the separator is put into operation again.

If the shut-down period has been longer than 12 months, a Major Service (MS) should be carried out.

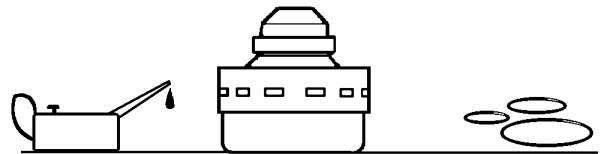
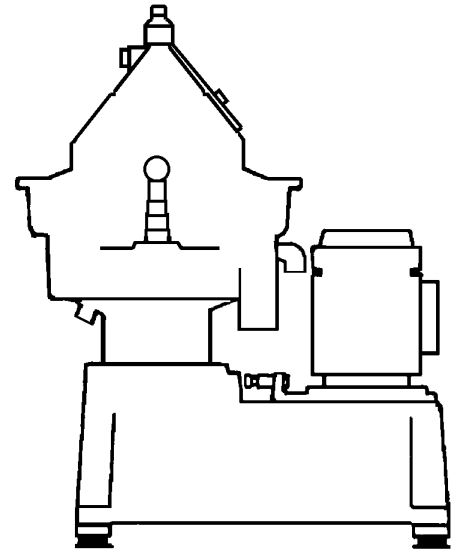

Remove the bowl if the separator is left at standstill for more than one week.

4 Dismantling/Assembly

Contents

4.1 Inlet/outlet and bowl	68
4.1.1 Inlet/outlet and bowl – dismantling	71
4.1.2 Inlet/outlet and bowl – assembly	76
4.2 Bowl spindle and frame	86
4.2.1 Bowl spindle and frame – dismantling	86
4.2.2 Bowl spindle and frame – assembly	92
4.3 Friction coupling	100
4.3.1 Friction coupling – dismantling	101
4.3.2 Friction coupling – assembly	103
4.4 Flat belt and tightener	107
4.4.1 Belt replacement and tightening	107
4.5 Oil filling device	112
4.5.1 Dismantling/assembly	112
4.6 Water tank	113
4.7 Brake	113
4.7.1 Exploded view	113
4.7.2 Checking of friction element	114
4.8 Frame feet	115
4.8.1 Mounting of new frame feet	115

References to check points

In the text you will find references to the check point instructions in chapter 5. The references appear in the text as in the following example:

✓ Check point

3.3.10 Disc stack pressure, page 47.

In this example, look up check point **Disc stack pressure** for further instructions.



Switch off and lock power supply before starting *any* dismantling work.

S0051011

Tools

Special tools from the tool kit must be used for dismantling and assembly. The special tools are specified in the *Spare Parts Catalogue*.

Additional tools needed for dismantling but not included in the tool kit are shown here.

For bowl and bowl spindle

- 1** Screwdriver
- 2** Torque wrench (50 Nm) with socket 16 mm
- 3** Pliers for internal snap ring
- 4** Ball bearing puller
- 5** Screw vice with copper liners
- 6** Adjustable wrench, length approx. 400 mm
- 7** Adjustable wrench or spanner, width of jaws 24 mm

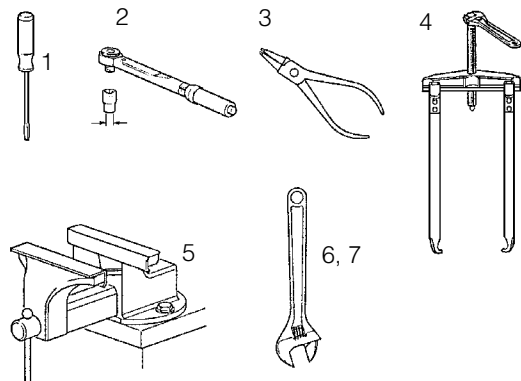

Two lifting slings, working load limit (WLL): >300 kg are also needed.

G0278821

For friction coupling and flat belt

- 1** *Pliers for internal snap ring*
- 2** *Pliers for external snap ring*
- 3** *T-handle, extension rod and socket 16 mm*
- 4** *Adjustable wrench or spanner, width of jaws 36 mm*
- 5** *Hammer*

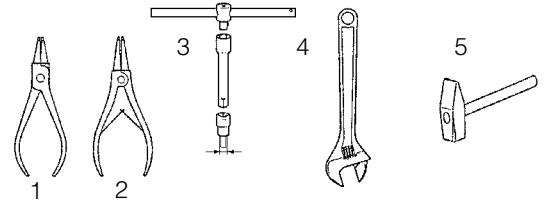

4.1 Inlet/outlet and bowl



Entrapment hazard

To avoid accidental start, switch off and lock power supply before starting any dismantling work.

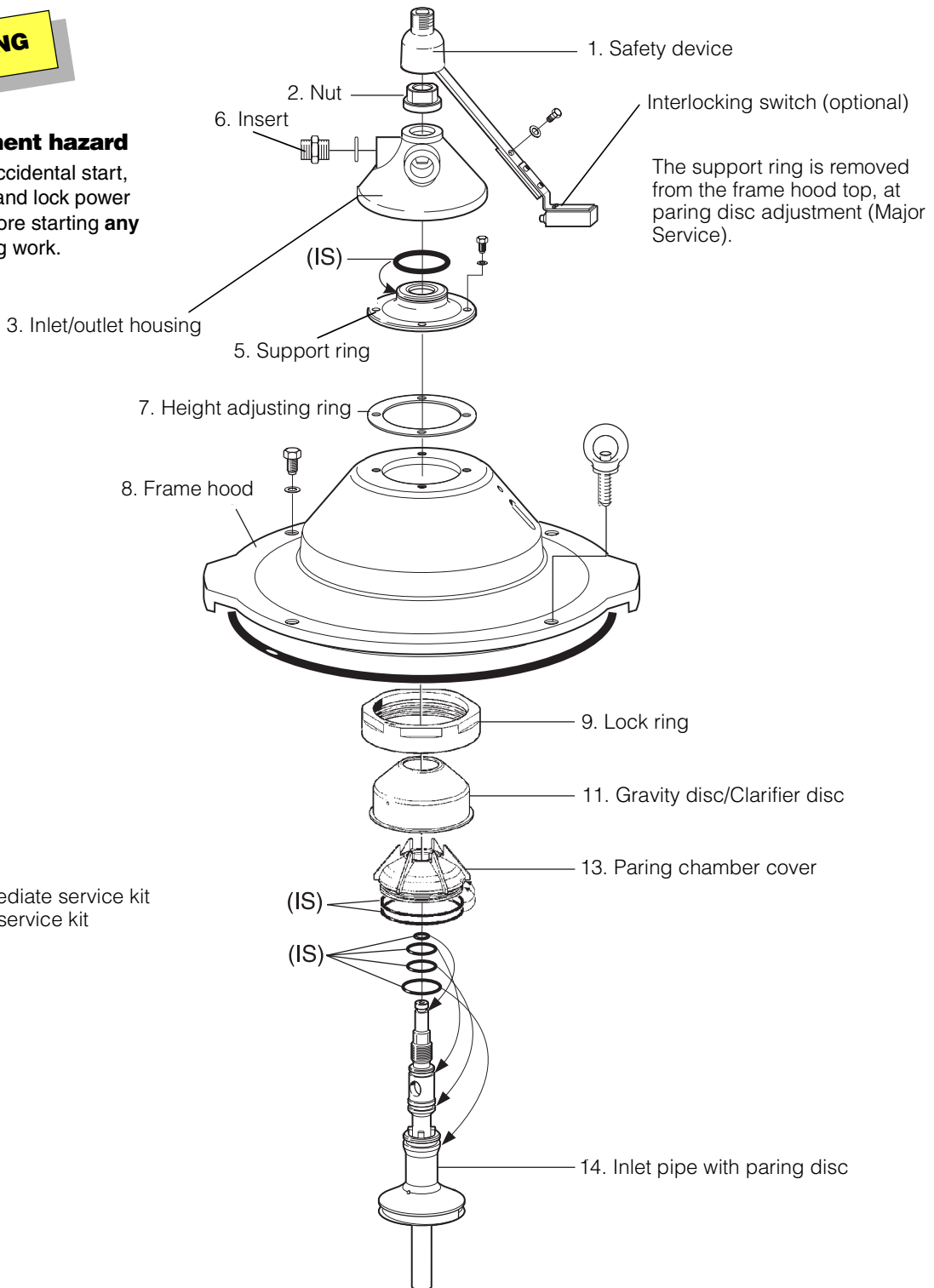

IS Intermediate service kit
MS Major service kit

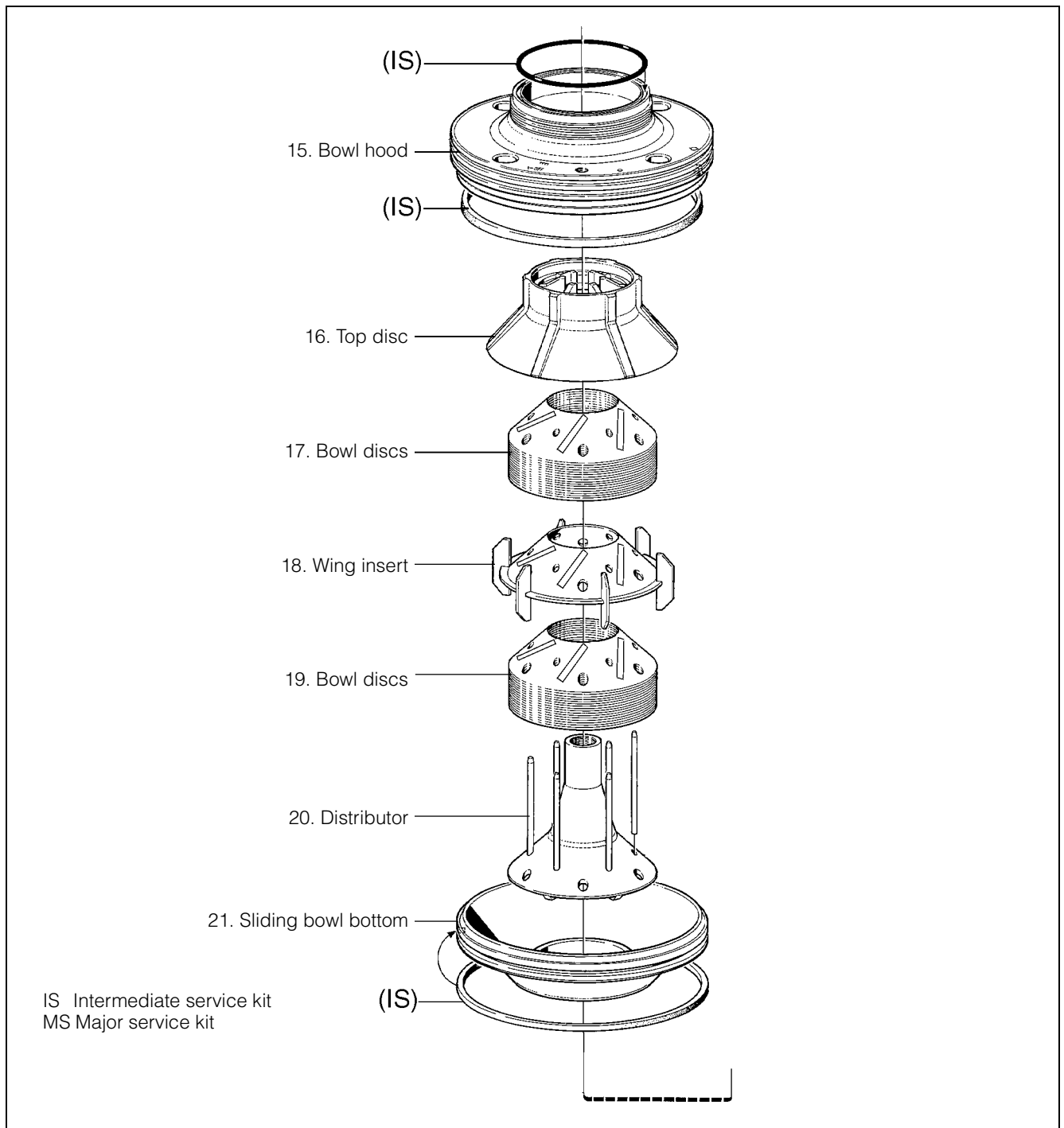

G 0887751

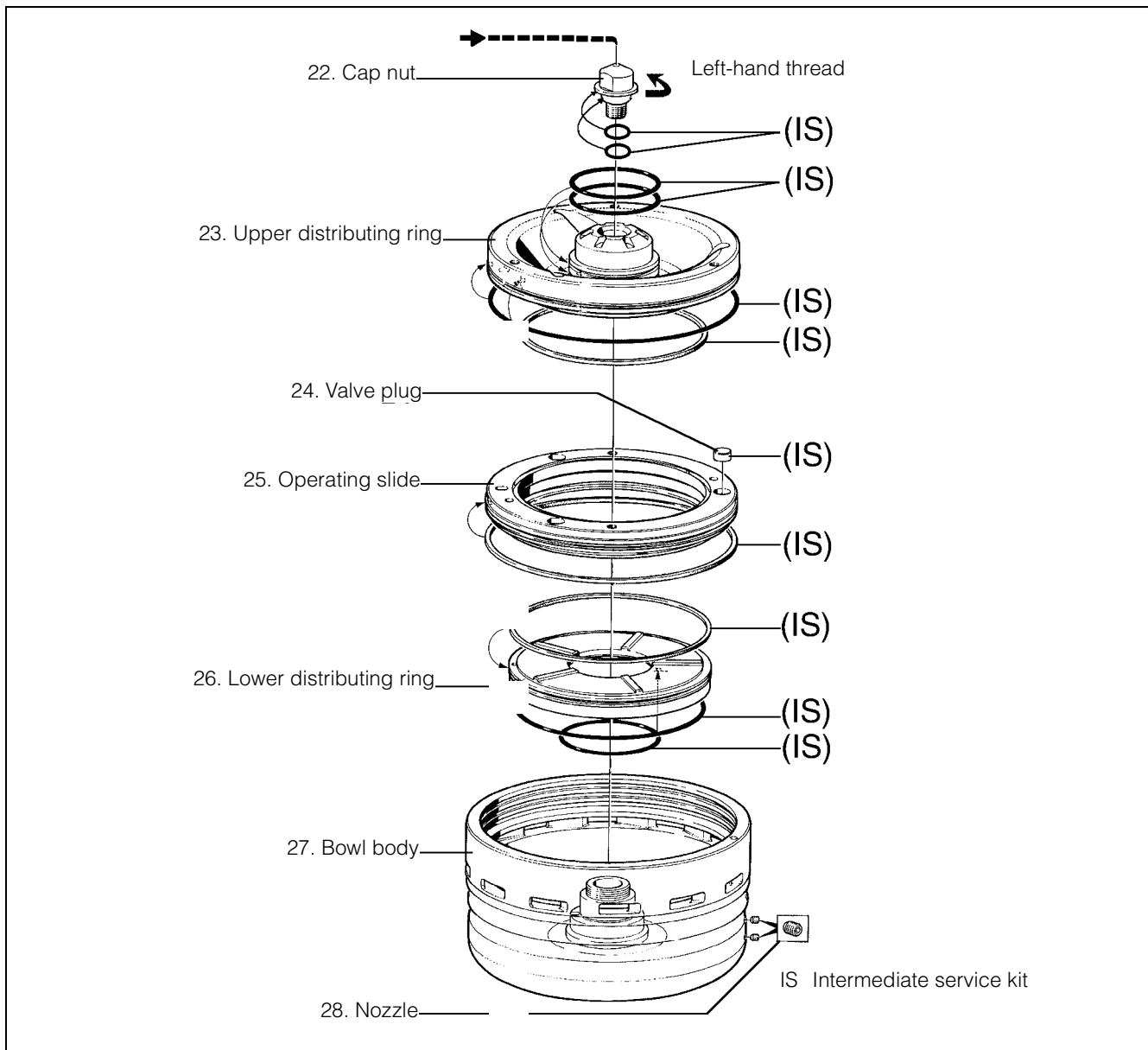

G0074251

4.1.1 Inlet/outlet and bowl – dismantling

The frame hood and the heavy bowl parts must be lifted by means of a hoist. Position the hoist exactly above the bowl centre. Use an endless sling and a lifting hook with catch.

The parts must be handled carefully. Don't place parts directly on the floor, but on a clean rubber mat, fibreboard or a suitable pallet.

- 1 Remove safety device and look through the slot in the frame hood to see if the bowl still rotates.



Entrapment hazard

Make sure that rotating parts have come to a complete standstill before starting any dismantling work.

The bowl parts can remain very hot for a considerable time after the bowl has come to a standstill.

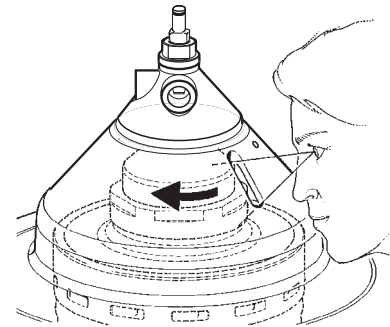
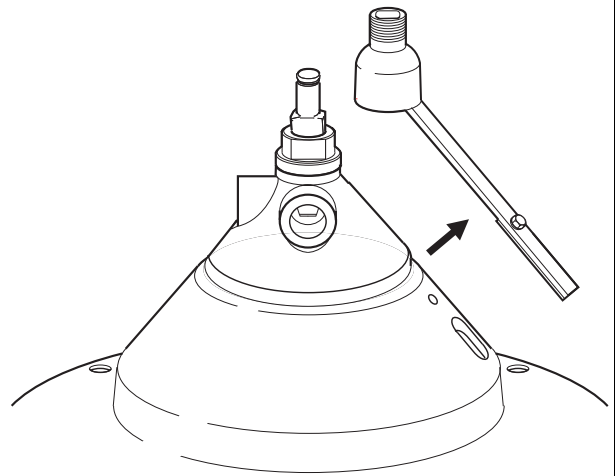

G0819751

G0467361

- 2 Unscrew nut clockwise and lift off inlet- outlet housing together with the connecting hoses. When removing the connecting hoses, do not drop the washer.

Left-hand thread!

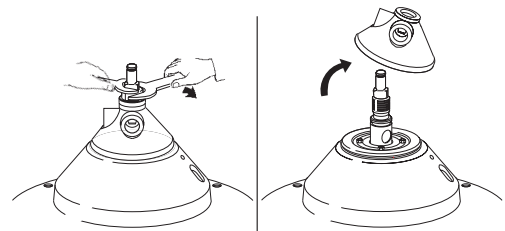

G0821531

- 3** Remove the bolts and lift off frame hood (8).
- 4** Unscrew lock ring (9) clockwise by using the special tool; spanner for lock ring.
- Left-hand thread!**

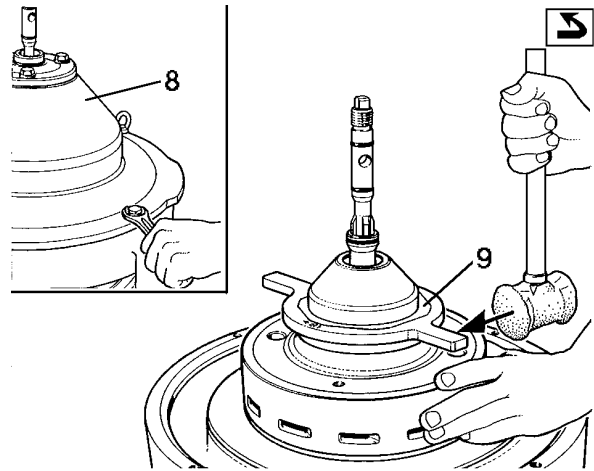

G0070021

- 5** Lift off gravity disc (clarifier disc) (11).
- 6** Carefully prise loose paring chamber cover (13) by using a screwdriver. Lift off the paring chamber cover.

NOTE

If the gravity disc has to be replaced owing to changed operating conditions, see **5.8.2 Gravity disc nomogram, page 141**.

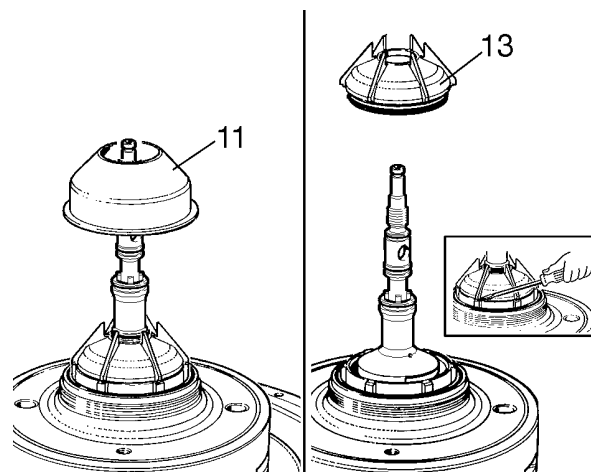

G0070131

- 7** Lift out inlet pipe (14) with the paring disc.

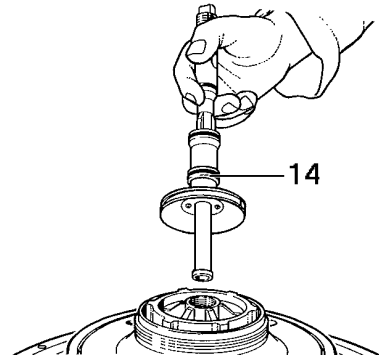

G0070221

- 8** Preparations for unscrewing of bowl hood (15):

- Fit the spanner to the bowl hood and secure it with the bolt (a).
- Fit the compression tool and screw down the central screw (b) until it stops
- Compress the disc stack by tightening the nut (c) firmly.

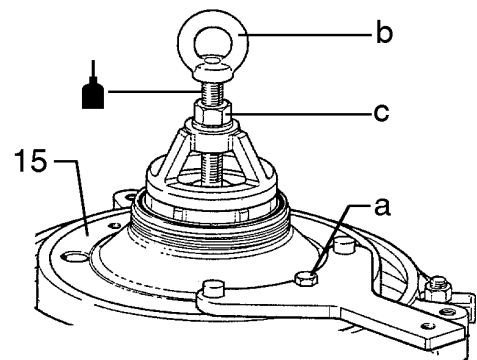

G0167121

NOTE

**Use the compression tool as instructed.
Use of substitute tools can damage the equipment.**

- 9** Unscrew bowl hood (15) clockwise by using a tin hammer.

Left-hand thread!

- 10** Lift off the bowl hood with the spanner still attached.

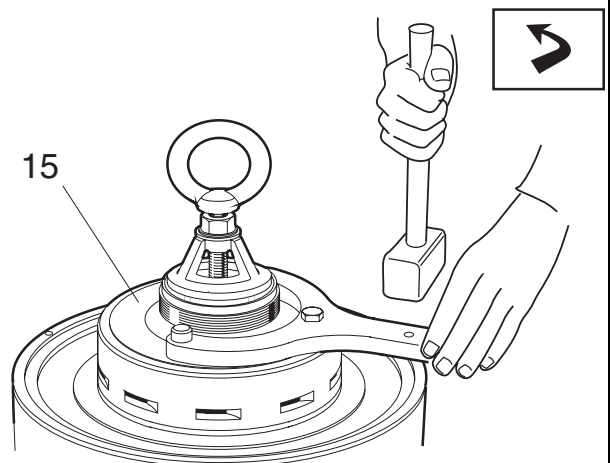

G0357411

- 11** Lift out the top disc, the bowl discs with wing insert and the distributor.
Screw the nut of the compression tool up against the eye bolt, turn the unit with the tool still attached upside down and hit it against a firm base. This will facilitate loosening of the top disc.

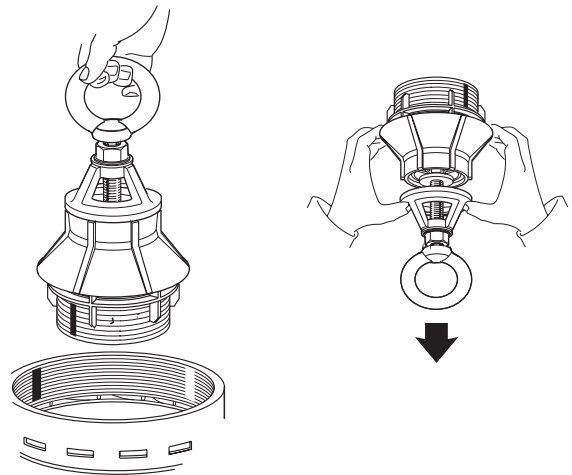

G0357521

- 12** Lift out sliding bowl bottom (21) using the special tool.
Ease the sliding bowl bottom off with the central screw of the tool. If necessary, knock on the handle.

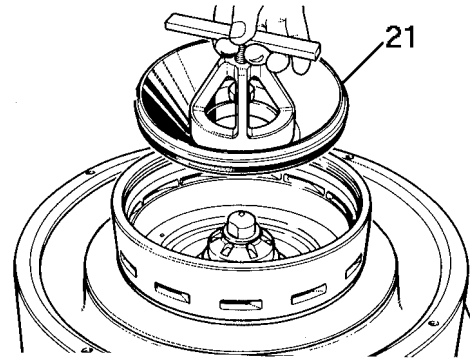

G0072031

- 13** Unscrew cap nut (22).

Left-hand thread!

- 14** Remove upper distributing ring (23) using the special tool.
Detach the distributing ring either:
- by jerking, or
 - by tightening the nuts equally

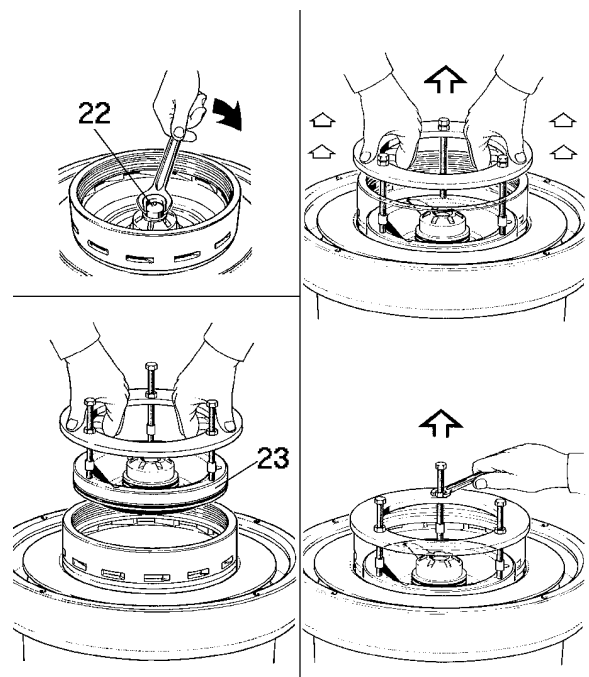

G0070631

- 15** Lift out operating slide (25) using the special tool: lifting bolts for operating slide.

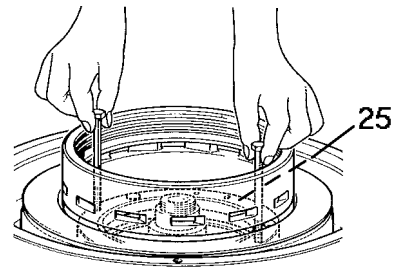

- 16** Lift out lower distributing ring (26).

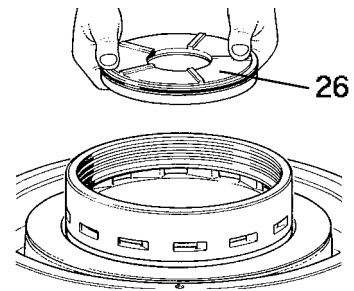

- 17** Lift out bowl body (27) using the special tool.

- 18** Ease the bowl body off with the central screw of the tool. If necessary, knock on the handle.

- 19** Soak and clean all parts thoroughly in suitable cleaning agent, see [3.7.1 Cleaning agents](#), page 54.

- 20** Clean nozzles (28) in bowl body (27) using soft iron wire of maximum 1,2 mm diameter, see [3.3.4 Discharge mechanism](#), page 40.

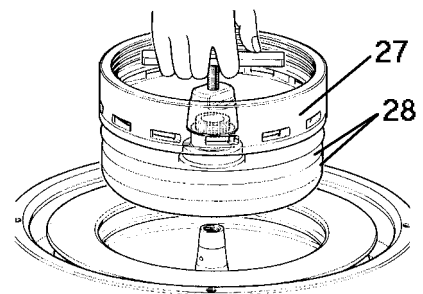

NOTE

Dirt and lime deposits in the sludge discharge mechanism can cause discharge malfunction or failing discharge.

- 21** Remove O-rings and replace them with spares from the intermediate service kit (IS).

4.1.2 Inlet/outlet and bowl – assembly

Make sure that the following check points are carried out before and during assembly of the separator bowl.

Check point

- 3.3.1 Corrosion, page 36,
- 3.3.2 Erosion, page 38,
- 3.3.3 Cracks, page 39,
- 3.3.4 Discharge mechanism, page 40,
- 3.3.6 Spindle top cone and bowl body nave, page 43,
- 3.3.7 Threads of inlet pipe, paring disc, page 43,
- 3.3.8 Threads on bowl hood and bowl body, page 44,
- 3.3.10 Disc stack pressure, page 47,
- 3.4.1 Paring disc height adjustment, page 48.

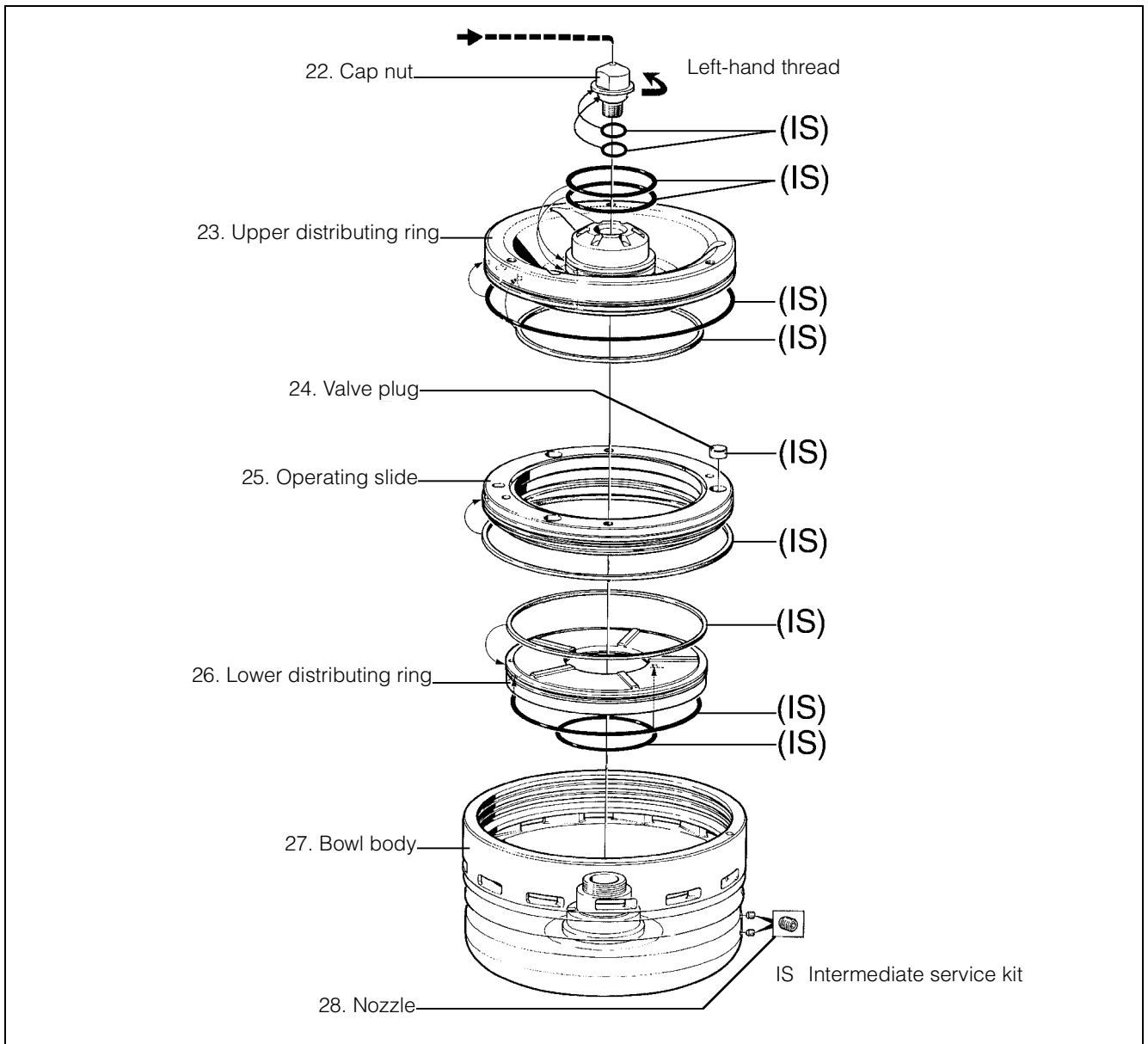

G0074251

IS Intermediate service kit
MS Major service kit

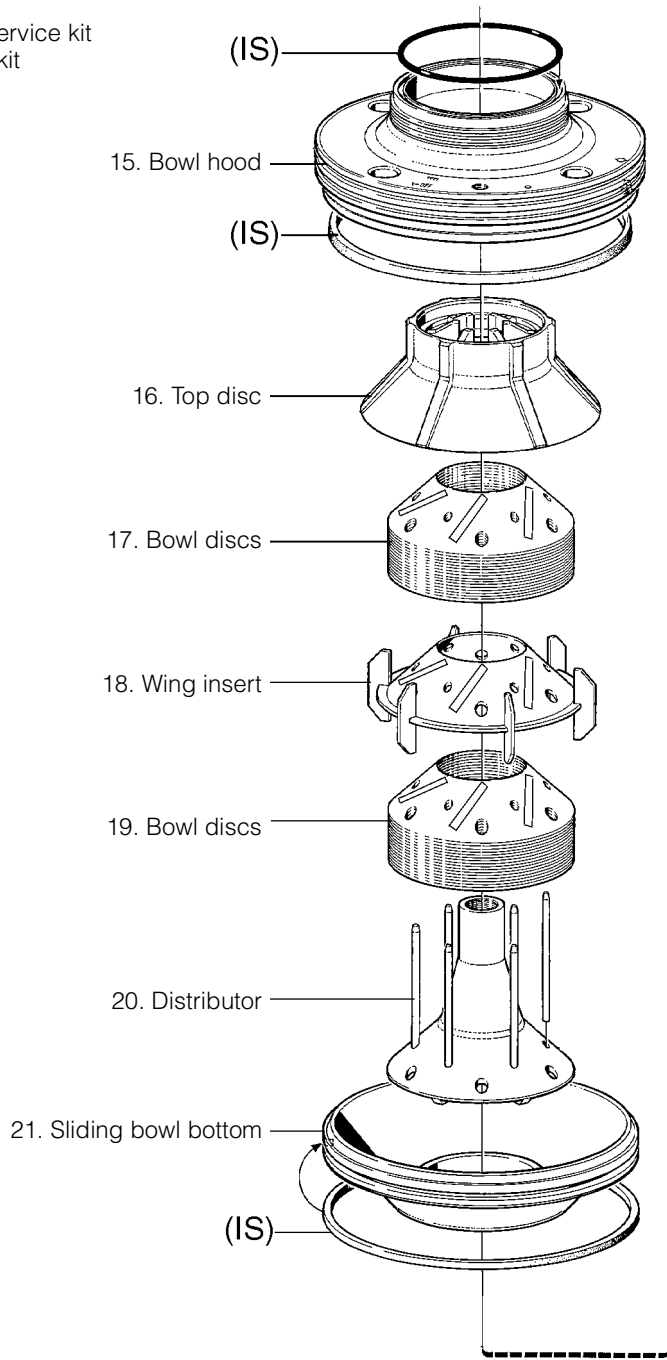

NOTE

Be sure bowl parts are not
interchanged.

Out of balance vibration
will reduce ball bearing
life.

G0687751

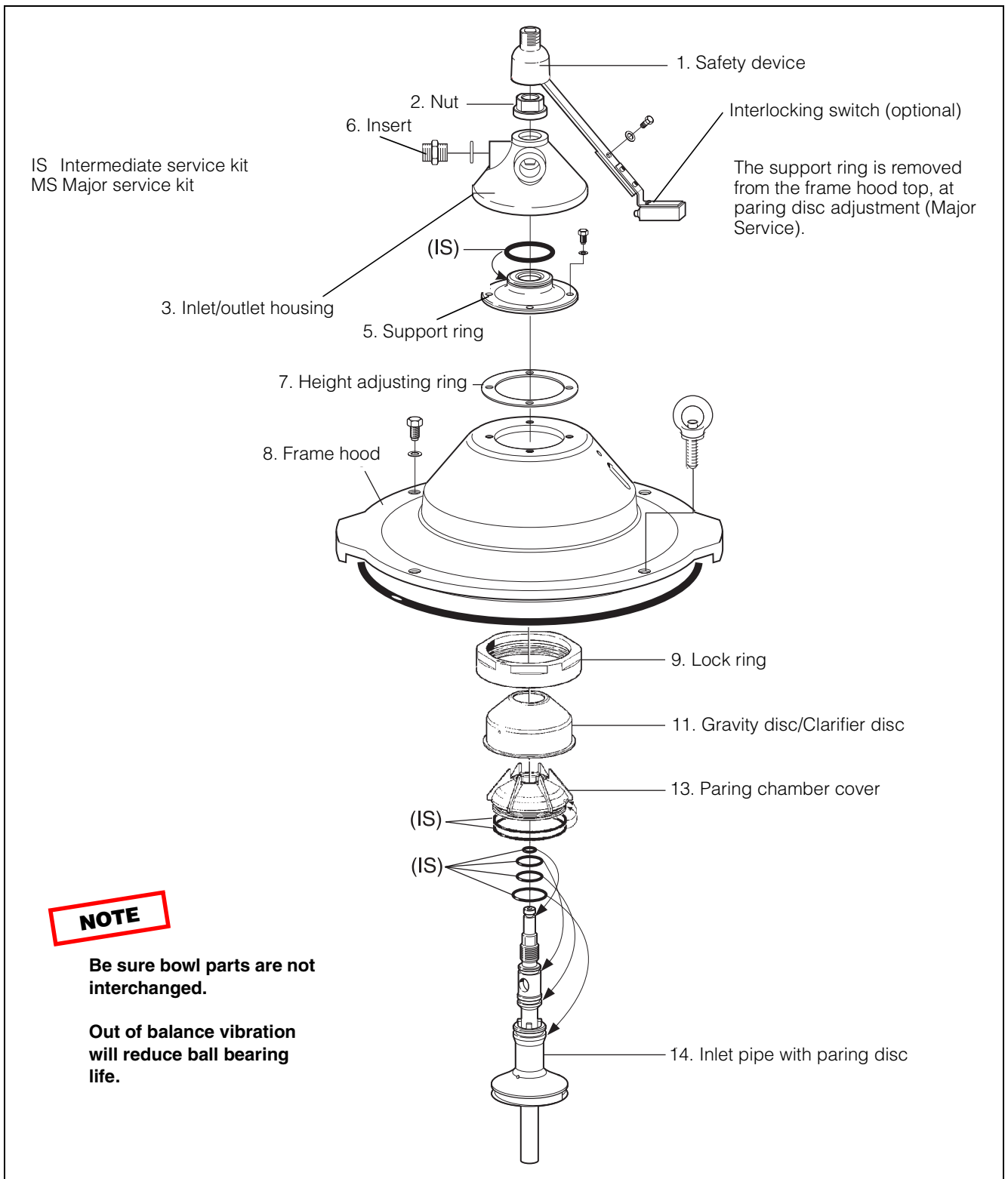

1 Clean the hollow part (b) of the spindle top and the radial hole (a). Wipe clean the spindle top and nave bore in the bowl body. Apply oil to the tapered end of the spindle, smear the oil over the surface and wipe off surplus with a clean cloth.

2 Clean the nozzles in the bowl body, see [3.3.4 Discharge mechanism, page 40](#).

Check point

[3.3.6 Spindle top cone and bowl body nave, page 43](#) and [3.3.9 Priming of bowl parts, page 46](#).

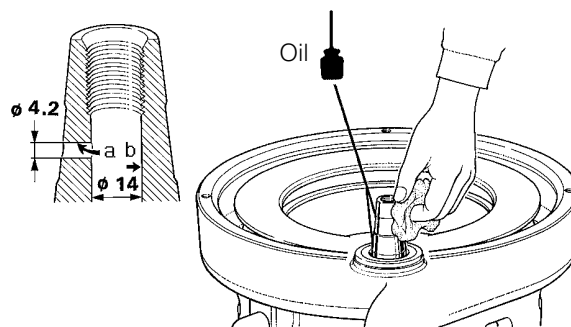

G0071721

3 Fit the bowl body (27) on the spindle. Avoid damaging the spindle cone.

- Attach the special lifting tool to the bowl body nave.
- Screw down the central screw of the tool, then lower the bowl body until the screw rests on the spindle top.
- Screw up the central screw and the bowl body will sink down on the spindle cone.

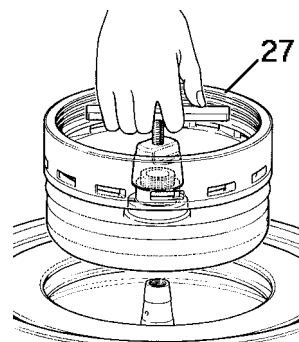

G0071831

4 Place the lower distributing ring (26) in the bowl body.

Using the lifting bolts fit the operating slide (25).

Make sure that the seal rings lie concentrically in their grooves.

If replacing valve plugs (24), use a rubber mallet.

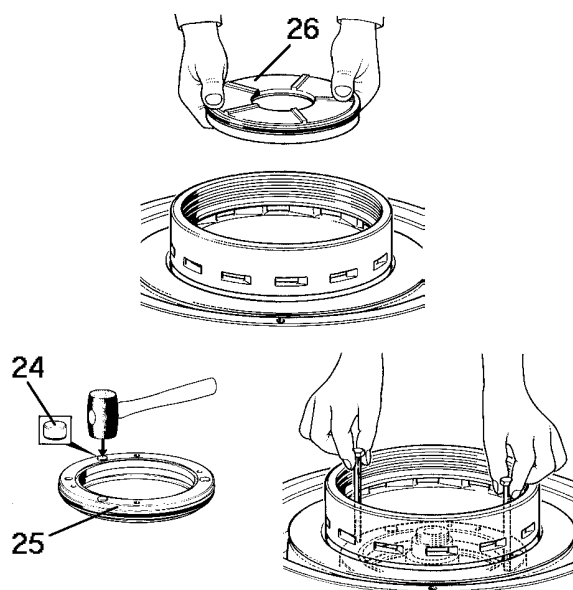

G0071841

- 5** Fit the upper distributing ring so that drill mark (a) is in line with hole (c) on the distributing ring.

When the distributing ring is in correct position the guide pin (b) will enter hole (c).

NOTE

The two guide pin (b) in the distributing ring have to be fitted properly in the hole (c).

Check the distance "A". If the play is larger than 2 mm the guide pins have not entered the hole properly.

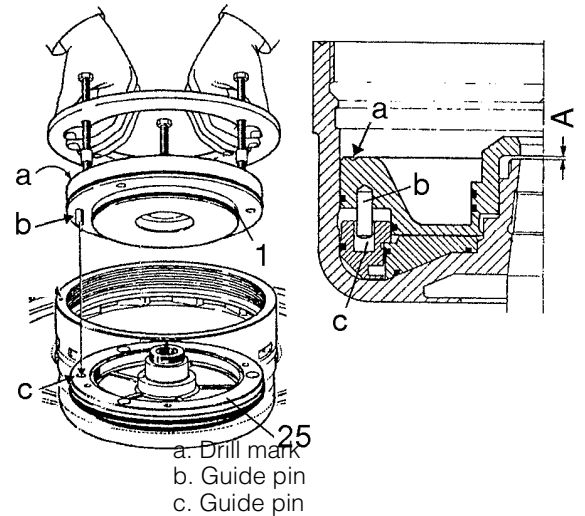

- 6** Screw cap nut (22) counter-clockwise onto the spindle.
Tighten firmly.

Left-hand thread!

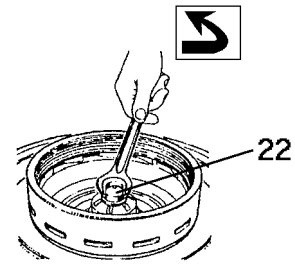

- 7** Fit sliding bowl bottom (21).
Make sure that the square seal ring lies concentrically in its groove.
Press the sliding bowl bottom down on the upper distributing ring.

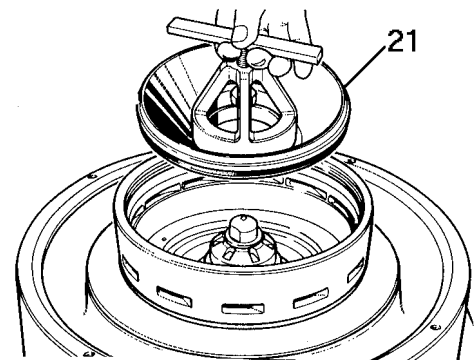

Check point

Before assembling the bowl discs, check the threads of the bowl hood and bowl body, see **3.3.8 Threads on bowl hood and bowl body, page 44.**

- 8** Assemble the bowl discs with wing insert and top disc on the distributor. Note the angular positioning (six options). Ensure that the pins in the distributor fit properly into the holes of the top disc.
- 9** Preparations for lifting in the disc stack
 - Fit the compression tool and screw down the central screw (a) until it stops
 - Tighten the compression nut by hand
- 10** Fit the disc stack assembly in the bowl body. Make sure that the cuts in the wings on the underside of the distributor fit properly in the corresponding lugs of the bowl.

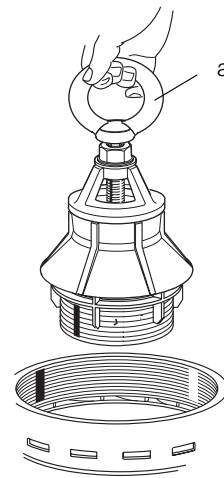

G0357561

11 Fit bowl hood (15):

- Apply a thin layer of Molykote Paste 1000 to threads and on contact and locating surfaces.
- Fit the spanner for the bowl hood and secure it with the bolt (a).
- Screw on the bowl hood by hand.

Left-hand thread!

Molykote
Paste1000

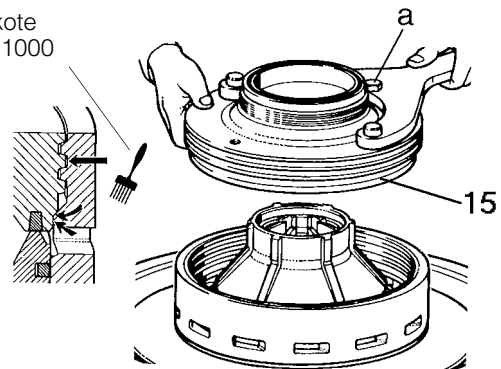

G0072231

- 12** Fit the compressing tool and screw down the central screw (a) until it stops.
Compress the disc stack by tightening the nut (b) firmly.

NOTE

Use the compression tool as instructed.
Use of substitute tools can damage the equipment.

Check point

3.3.10 Disc stack pressure, page 47.

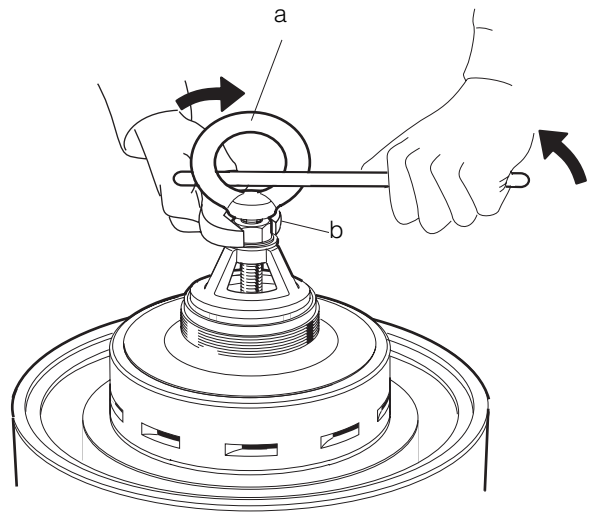

G0072361

- 13** Attach the spanner and tighten the bowl hood by using a tin hammer.
Strike the spanner handle until the bowl hood lies tightly against the bowl body. In a new bowl, the assembly marks now will be in line with each other.

WARNING**Disintegration hazard**

The assembly mark on the bowl hood must never pass the mark on the bowl body by more than 25°.

See also 3.3.8 Threads on bowl hood and bowl body, page 44.

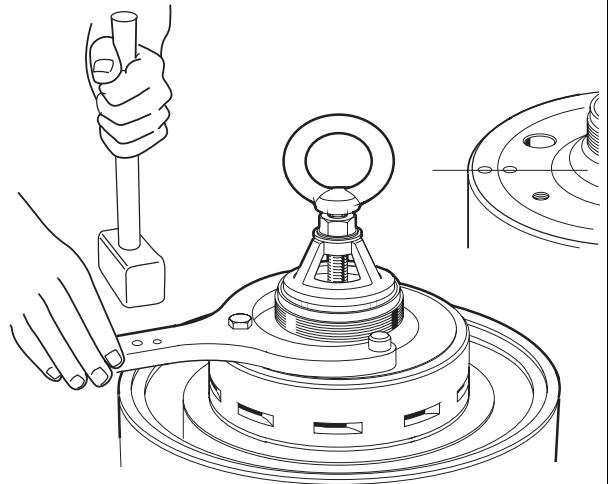

G0357711

- 14** Place inlet pipe (14) in the bowl.

Check point

3.3.7 Threads of inlet pipe, paring disc, page 43.

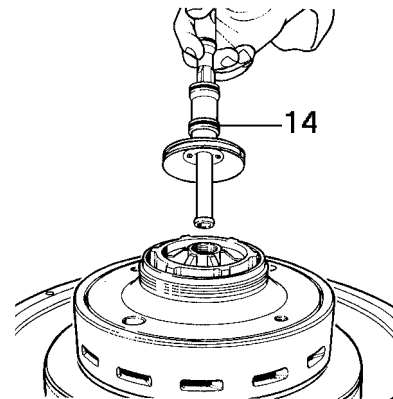

G0072721

15 Fit paring chamber cover (13) by pressing it down gently.

16 Assemble gravity disc/ clarifier disc (11).

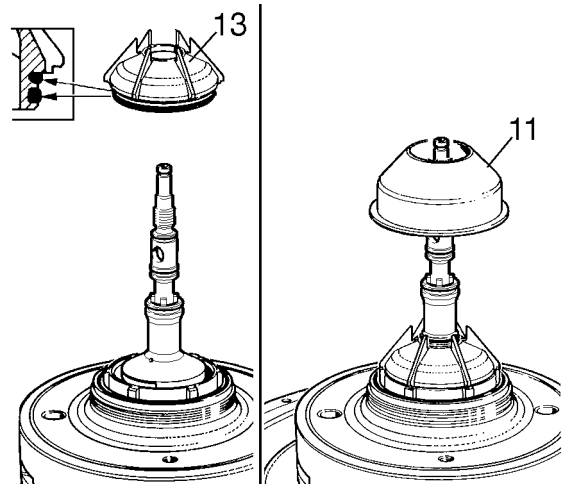

G0073341

17 Fit lock ring (9).

Apply a thin layer of Molykote Paste 1000 to the threads and on contact and locating surfaces.

Left-hand thread!

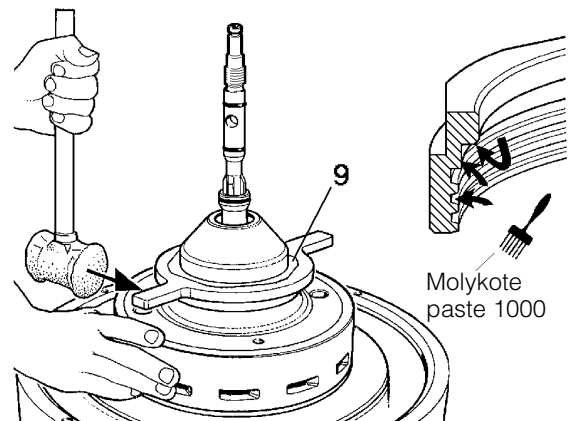

G0074331

18 Fit frame hood (8).

The two eye-bolts must be fitted in the holes nearest to the electric motor.

In case of Major Service remove the connecting housing and fit a new O-ring on the insert (2).

Check point

3.4.1 Paring disc height adjustment, page 48.

To be performed at Major Service and if the bowl spindle has been dismantled.

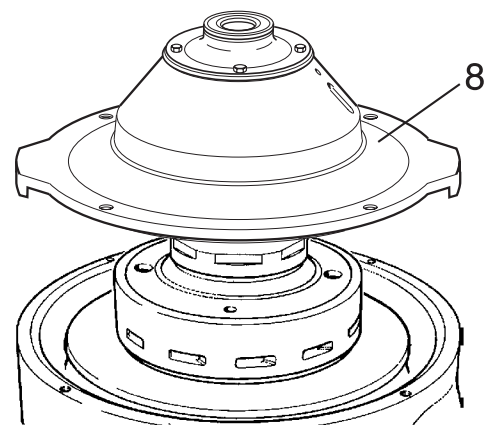

G0073581

- 19** Fit inlet/outlet housing.
Tighten nut.

Left-hand thread!

- 20** Then rotate the bowl by means of the flat belt.
If the bowl does not rotate freely or a scraping noise is heard, incorrect bowl assembly or incorrect height adjustment of the paring disc can be the cause.

NOTE

To avoid damage on the inlet pipe the tightening torque must not exceed 30 Nm.

- 21** Make sure that the gasket on the safety device is in position. If not, glue with Loctite 407.
Fit and secure safety device.
- 22** Fit the connecting hoses if they have been removed. Make sure to fit their gasket rings.
- 23** Fit the water tank on the frame bottom part if it has been removed.

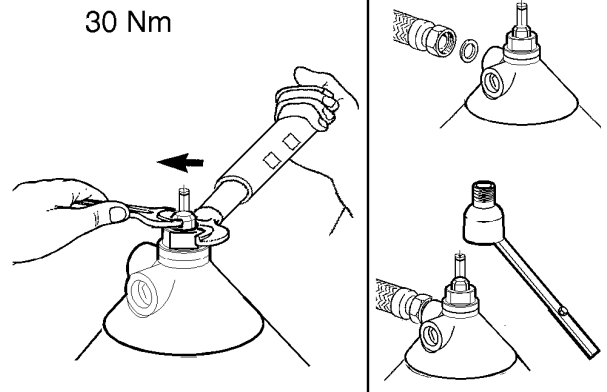

4.2 Bowl spindle and frame

4.2.1 Bowl spindle and frame – dismantling

Before dismantling the bowl spindle, the inlet and outlet housing, frame hood and bowl as well as the flat belt must be removed.

Before dismantling, in the case of Major Service, or if the separator vibrates while running, see

Check point

3.4.2 Radial wobble of bowl spindle, page 50.

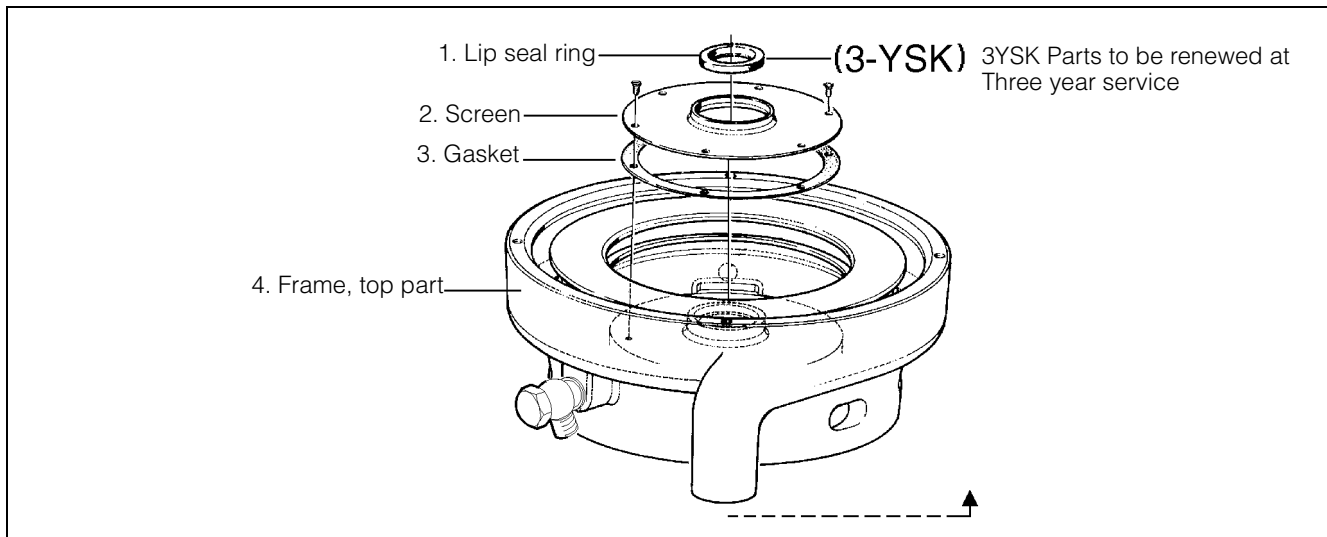

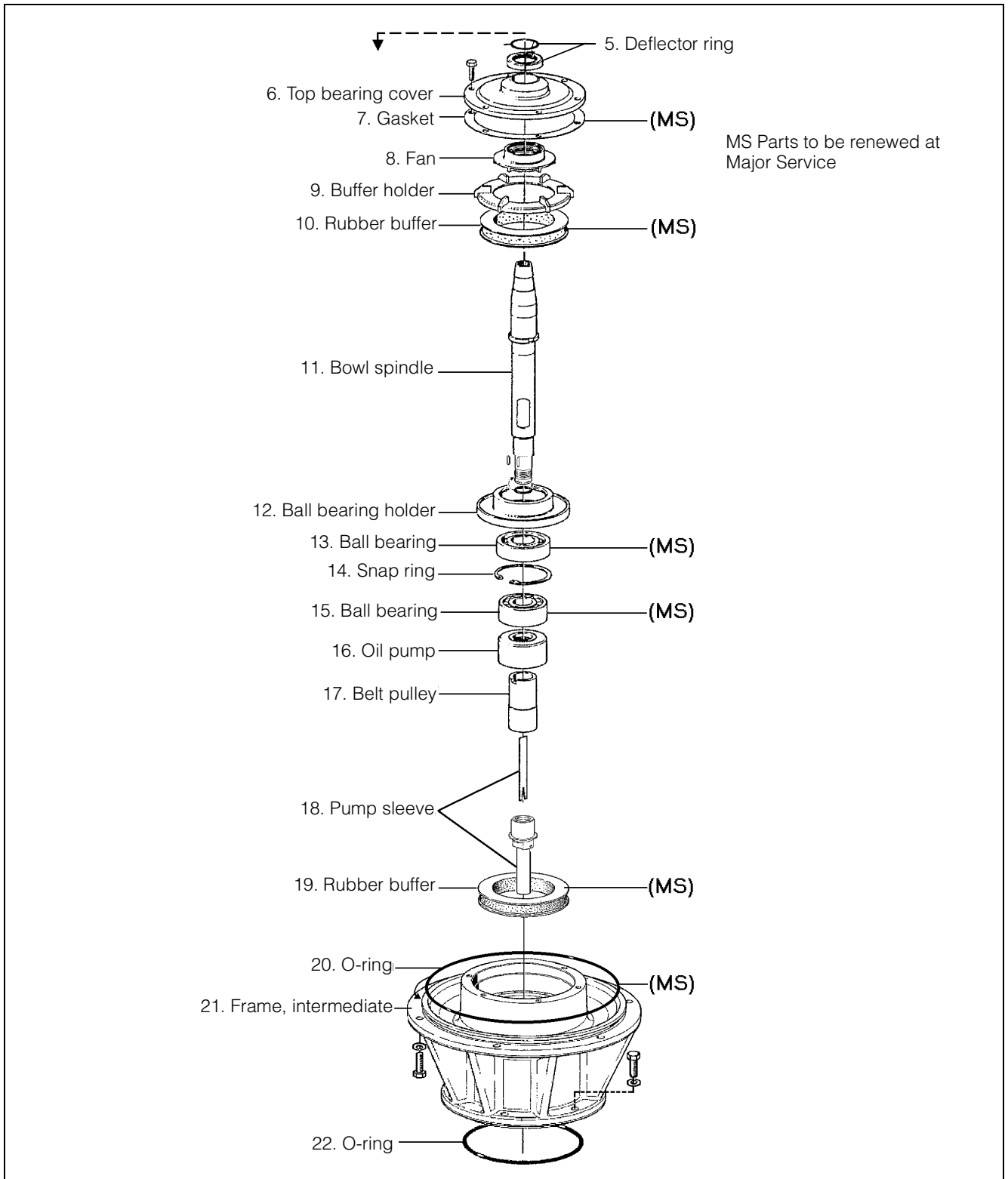

G01131A1

- 1** Loosen but do not remove the motor adapter screws.
- 2** Remove the water tank.
- 3** Remove the brake.
- 4** Remove the flat belt.

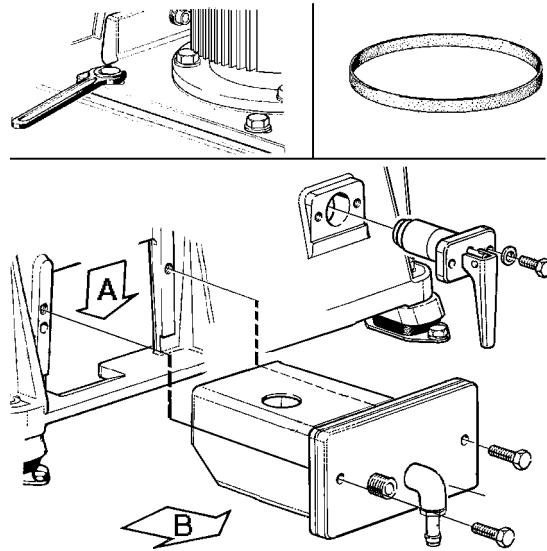

G01133E1

- 5** Remove the screws and lift off frame top part (4). Lip seal ring (1) must be removed in the case of 3-year service, or if found damaged.

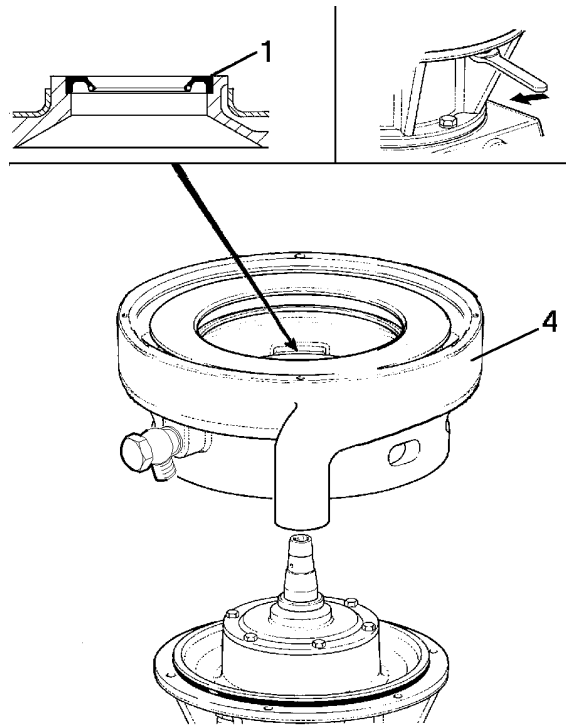

G0113461

- 6** Clean the bowl spindle cone in place and remove deflector ring (5).

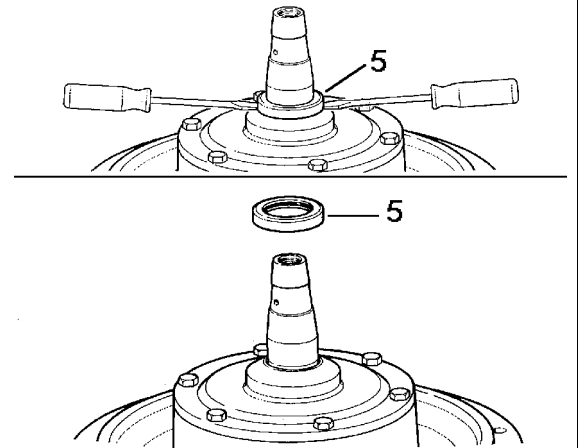

- 7** Remove, in the following sequence:

- Top bearing cover (6)
- Gasket (7)
- Fan (8)
- Buffer holder (9)
- Rubber buffer (10).

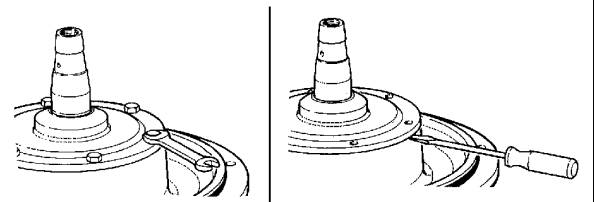

NOTE

Be very careful not to damage the wings of the buffer holder.

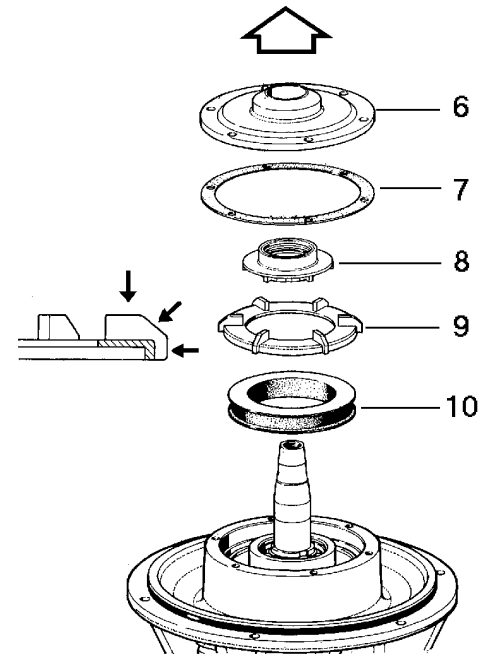

- 8** Screw the cap nut counter-clockwise (left-hand thread) onto the spindle top to protect the top and bore.

Lift out spindle assembly (11), rubber buffer (10) and O-ring (20).

Remove snap ring (14) by using a pair of pliers and pull off ball bearing holder (12).

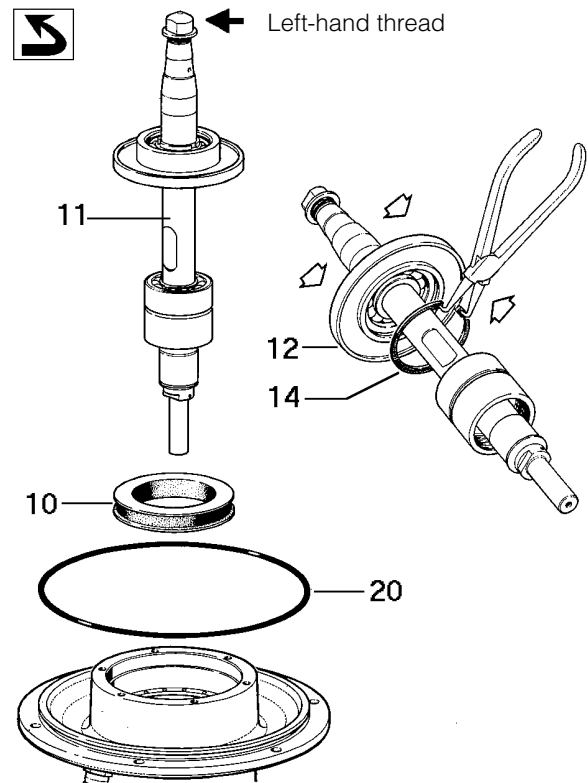

G0076132

- 9** Clamp the bowl spindle (11) in a screw vice. Remove the pump sleeve (18). When turning the spindle upside down there is a risk that the vane in the pump sleeve can slide down partly or entirely into the spindle. Therefore, after unscrewing the sleeve, check that the vane has not been damaged.

- 10** Remove the belt pulley (17). If the pulley has stuck proceed with point 10.

- 11** Lubricate the mounting/dismantling tool.

Fit the mounting/dismantling tool and screw it down as far as it will go (A).

Use a long spanner (450 - 650 mm) to press the belt pulley off the spindle (B).

Remove the oil pump (16) by hand, do not lose the flat key.

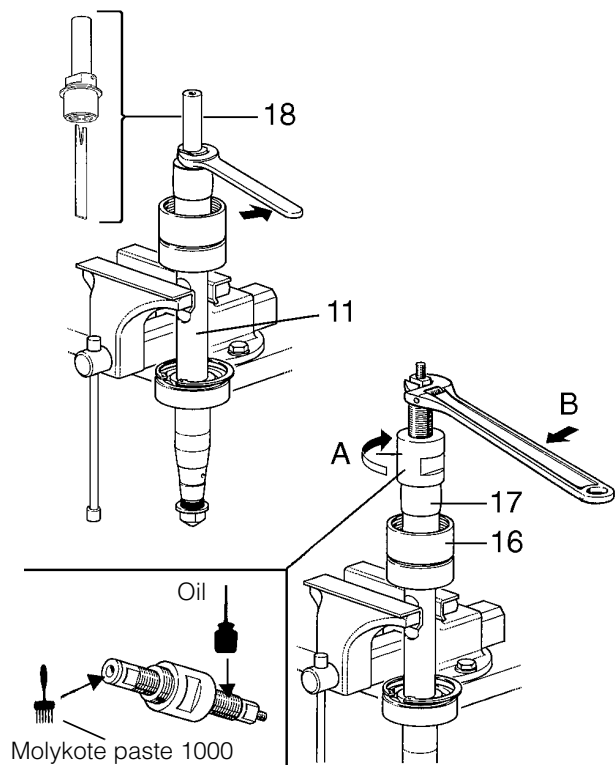

G0076251

- 12** Pull off ball bearing (15) using a puller and thrust washer.

Pull off bearing (13) using the special mounting tool and a hammer.

NOTE

Always discard a used bearing.

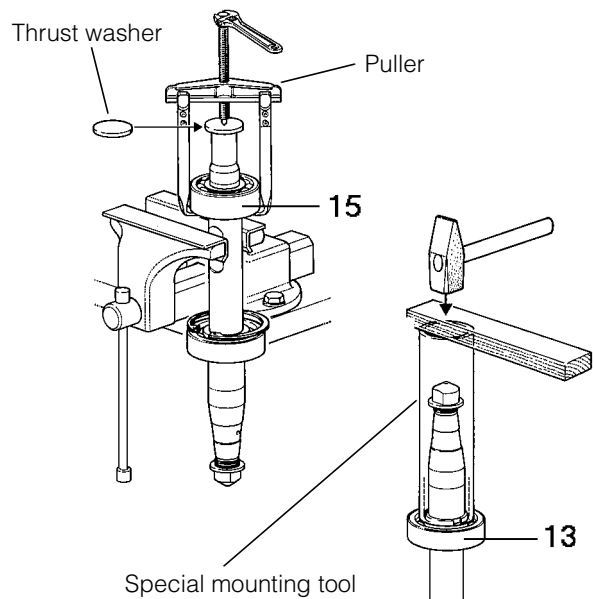

G0076321

In case of 3-year-service

- 13** Loosen the screws and lift off the frame intermediate part (21).

- 14** Discard the O-ring (22). This O-ring is not included in any service kit, but must be ordered separately.

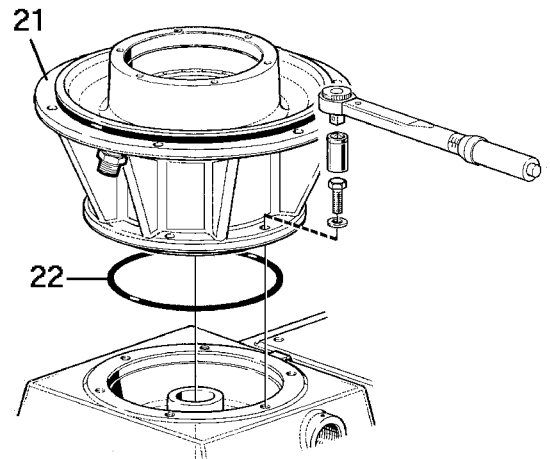

G0093791

15 Remove the screen (2) from the frame top part (4).

Discard the gasket (3). This gasket is not included in any service kit, but must be ordered separately.

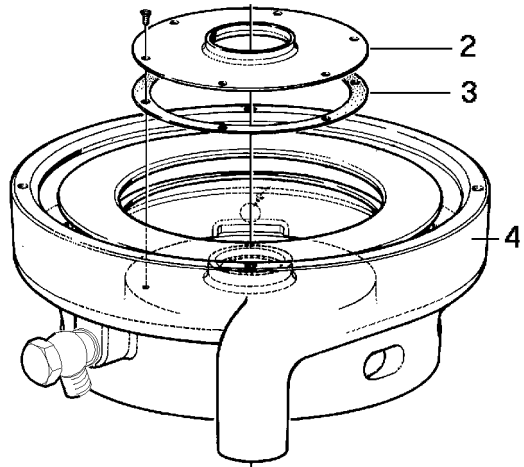

16 Clean the oil sump.

17 Clean all dismantled parts thoroughly in a degreasing agent and check for damage and corrosion.

Replace all parts supplied in the spare parts kits.

G0113771

4.2.2 Bowl spindle and frame – assembly

The bowl spindle and frame is assembled in reverse sequence to dismantling.

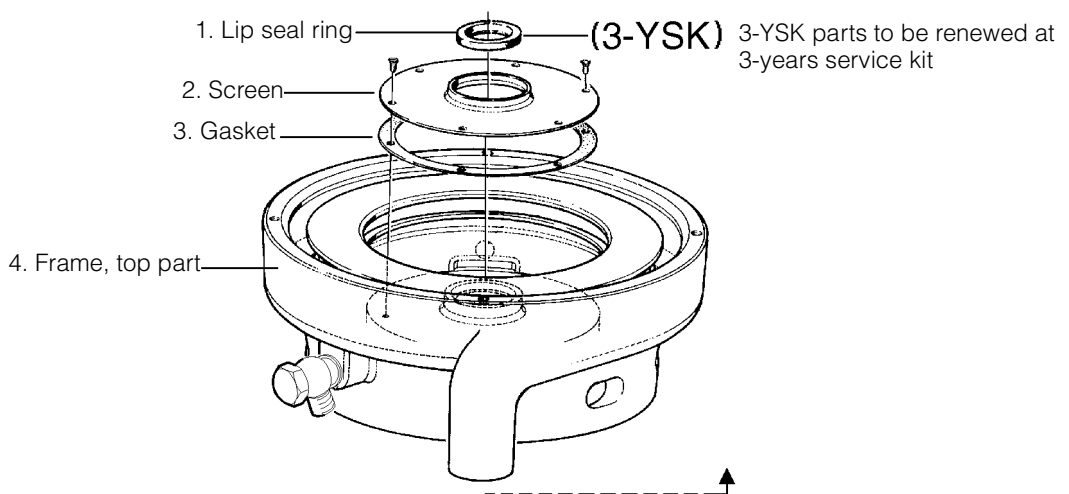

G01132A1

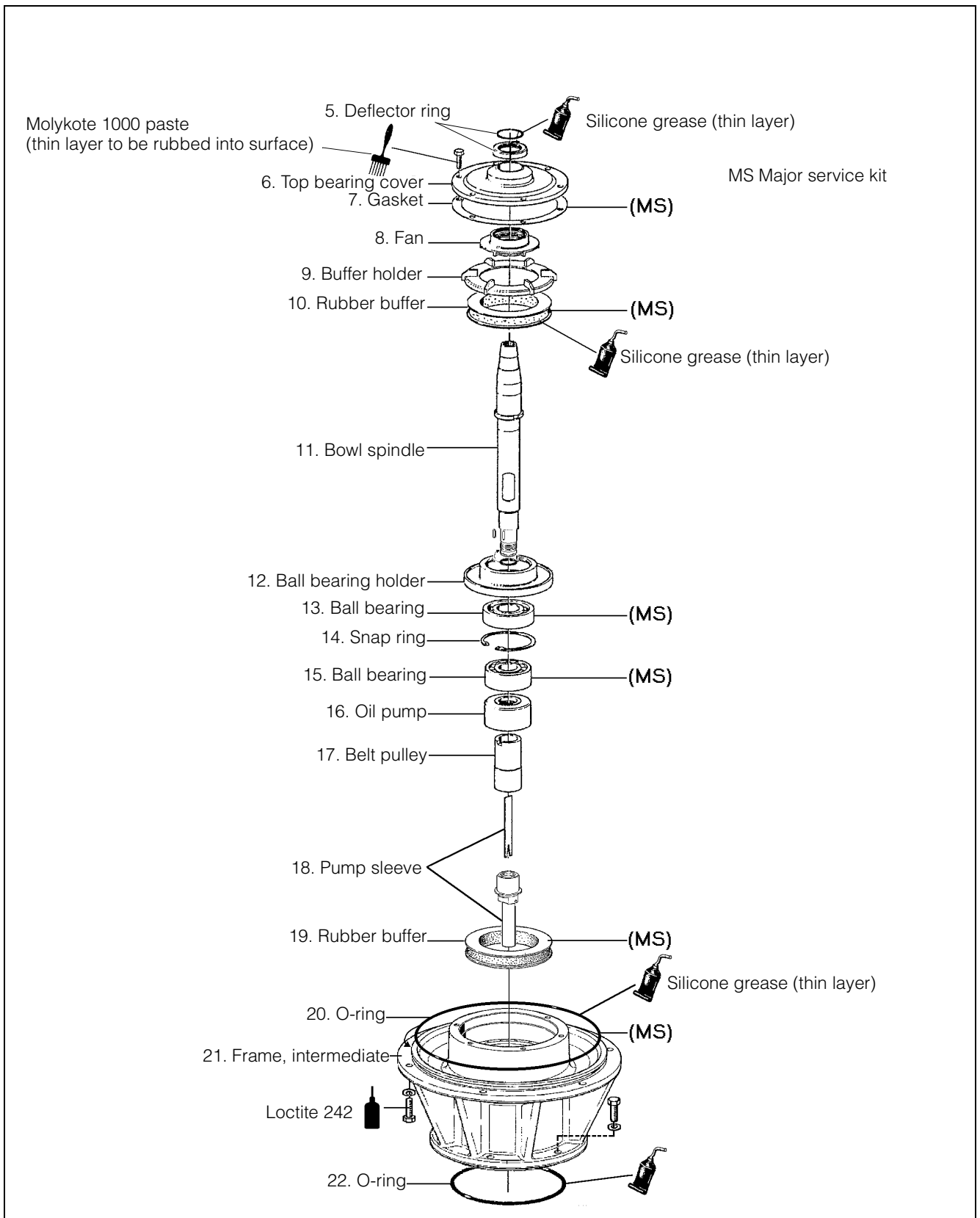

G 01131B1

In case of 3-year-service

- 1** Fit a new O-ring (22) and assemble the frame intermediate part (21).

Use a torque wrench and tighten the screws lightly crosswise at first. Then tighten all around to 45 Nm.

Secure the screws with Loctite 242.

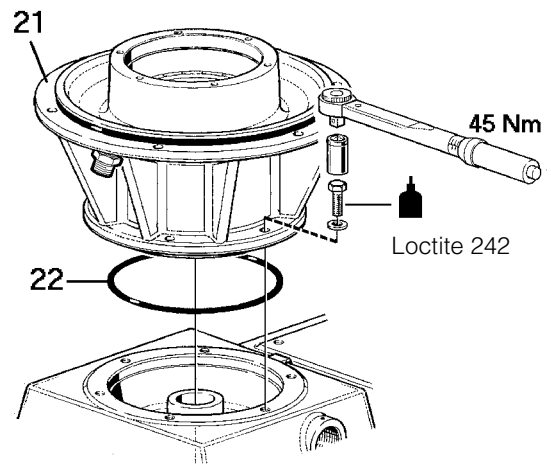

G0093781

- 2** Fit a new gasket (3).

Fit the screen (2).

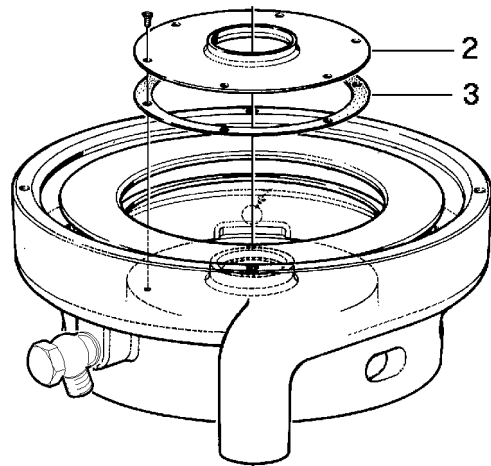

G0113761

- 3** Clear the spindle bore from dirt and lime deposits with the special reamer

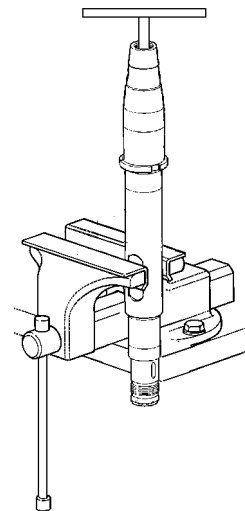

G0076341

- 4** Inspect the tapered end and the hollow part of the bowl spindle for wear and clean if necessary. Assemble ball bearings (13 and 15).

Heat the new ball bearings in oil to maximum 125 °C. Use the special mounting tool from the tool kit.

NOTE

Always fit new bearings.

If in doubt how to install roller bearings in a correct way, please see the detailed description in 3.10.1 Ball and roller bearings, page 60.

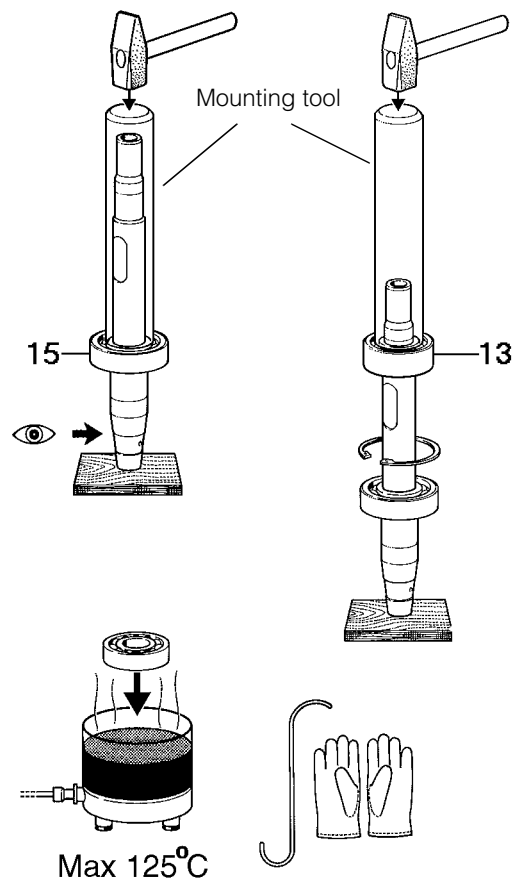

G0113831

- 5** Fit oil pump, flat key and belt pulley. Make sure that the recess in the belt pulley fits over the guide pin in the oil pump.

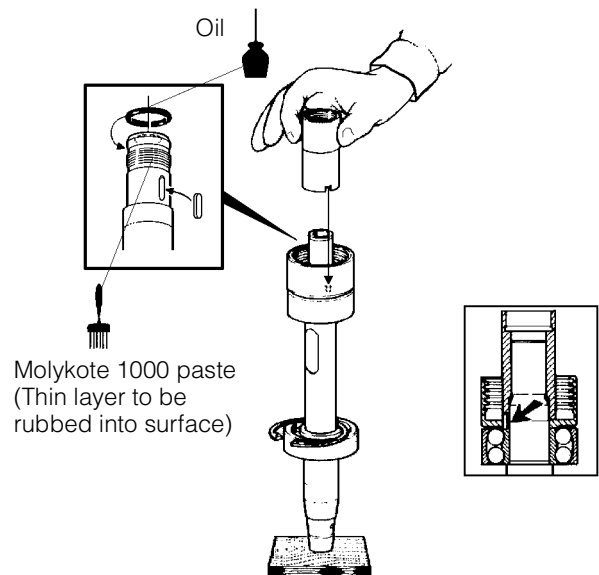

G0113941

- 6** Check that the radial hole (\varnothing 1 mm) in the pump sleeve is clean, and fit the pump.

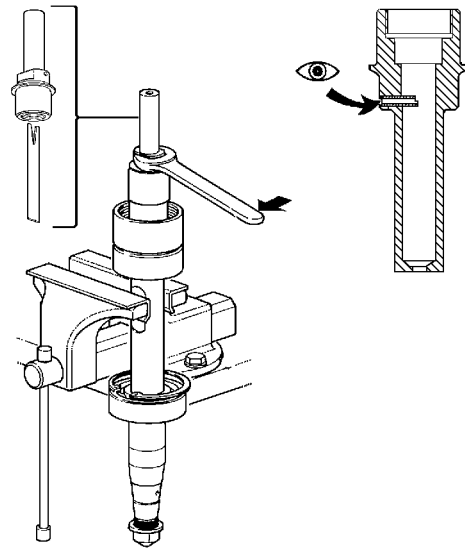

G0114341

- 7** Fit ball bearing holder (12) and secure it with snap ring (14).

Fit O-ring (20) and rubber buffer (19).

Lower spindle assembly (11) carefully into the separator intermediate frame.

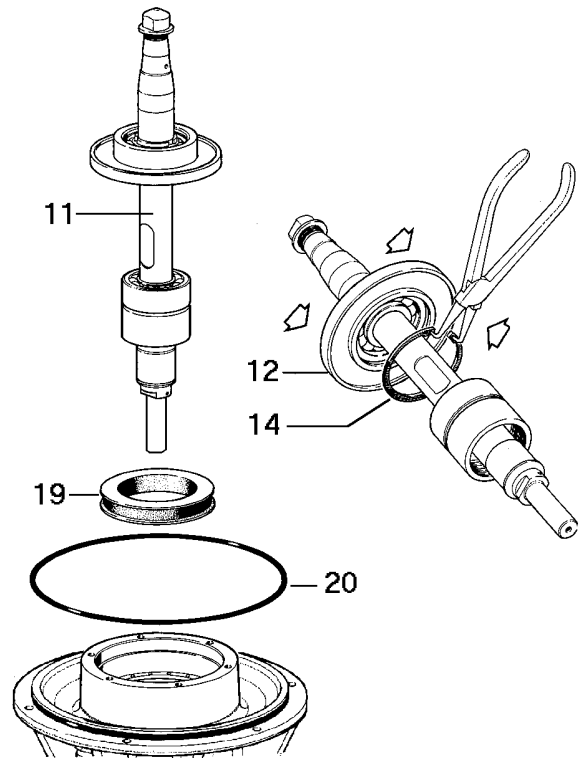

G0076122

8 Assemble, in the following sequence:

- Rubber buffer (10)
- Buffer holder (9)
- Fan (8)
- Gasket (7)
- Top bearing cover (6)

Make sure that the $\varnothing 3$ mm hole in fan (8) is clean and the lugs in the fan enter the recesses in the bowl spindle.

Before tightening, make sure that there is some play (a) between top bearing cover (6) and the frame. The play will disappear when the screws are tightened.

Tighten the screws sequentially (not crosswise) in order to successively compress the rubber buffers.

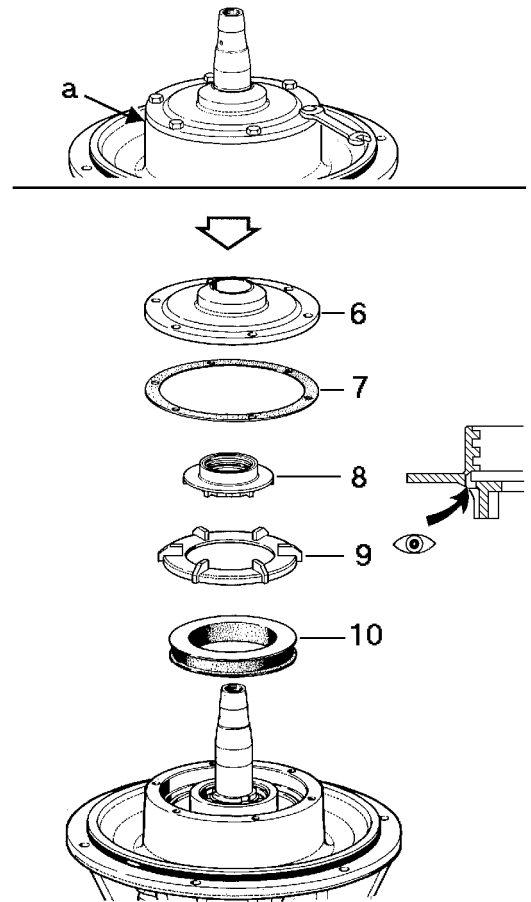
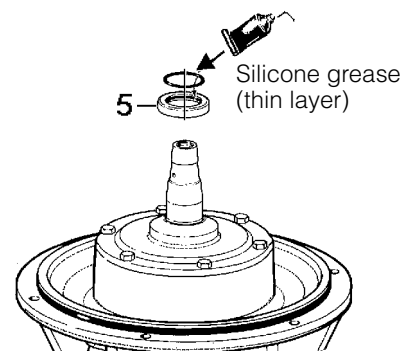
**9** Push down deflector ring (5) till it stops.

- 10** Assemble frame top part (4). If lip seal ring (1) has been removed, fit a new one before the frame top part is put in place.

Make sure the lip seal is turned the correct way. See illustration.

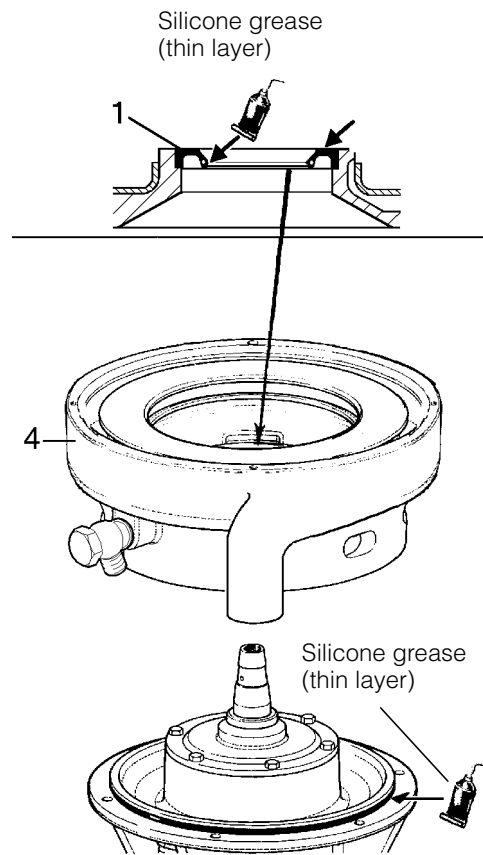

G0114661

- 11** Tighten the screws of the top frame using a torque wrench (width across flats 16 mm).

Tighten the screws slightly crosswise at first. Then tighten all around to 45 Nm.

Secure the screws with Loctite 242.

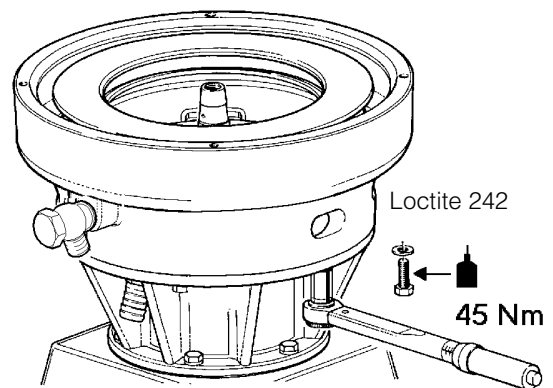

G0114751

- 12** Fit and adjust the flat belt, see *4.4.1 Belt replacement and tightening, page 107.*

Check point

3.4.2 Radial wobble of bowl spindle, page 50.

- 13** Fit the water tank and tighten the screws.

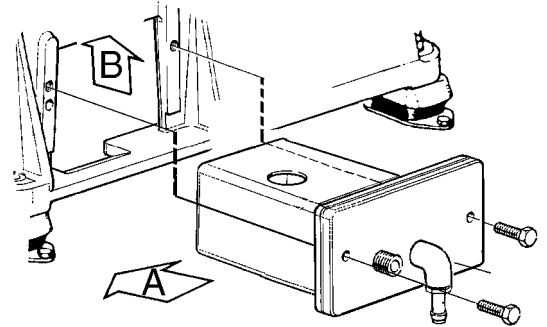
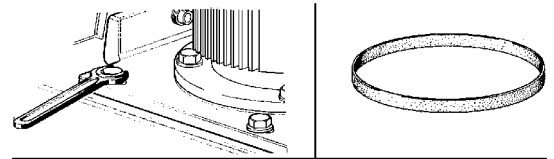

4.3 Friction coupling

If the separator does not attain full speed within about 2 minutes, the friction elements or the coupling may be worn or greasy. The friction elements must then be replaced with new ones or be thoroughly cleaned from grease.



Entrapment hazards

Make sure that rotating parts have come to a complete standstill before starting any dismantling work.

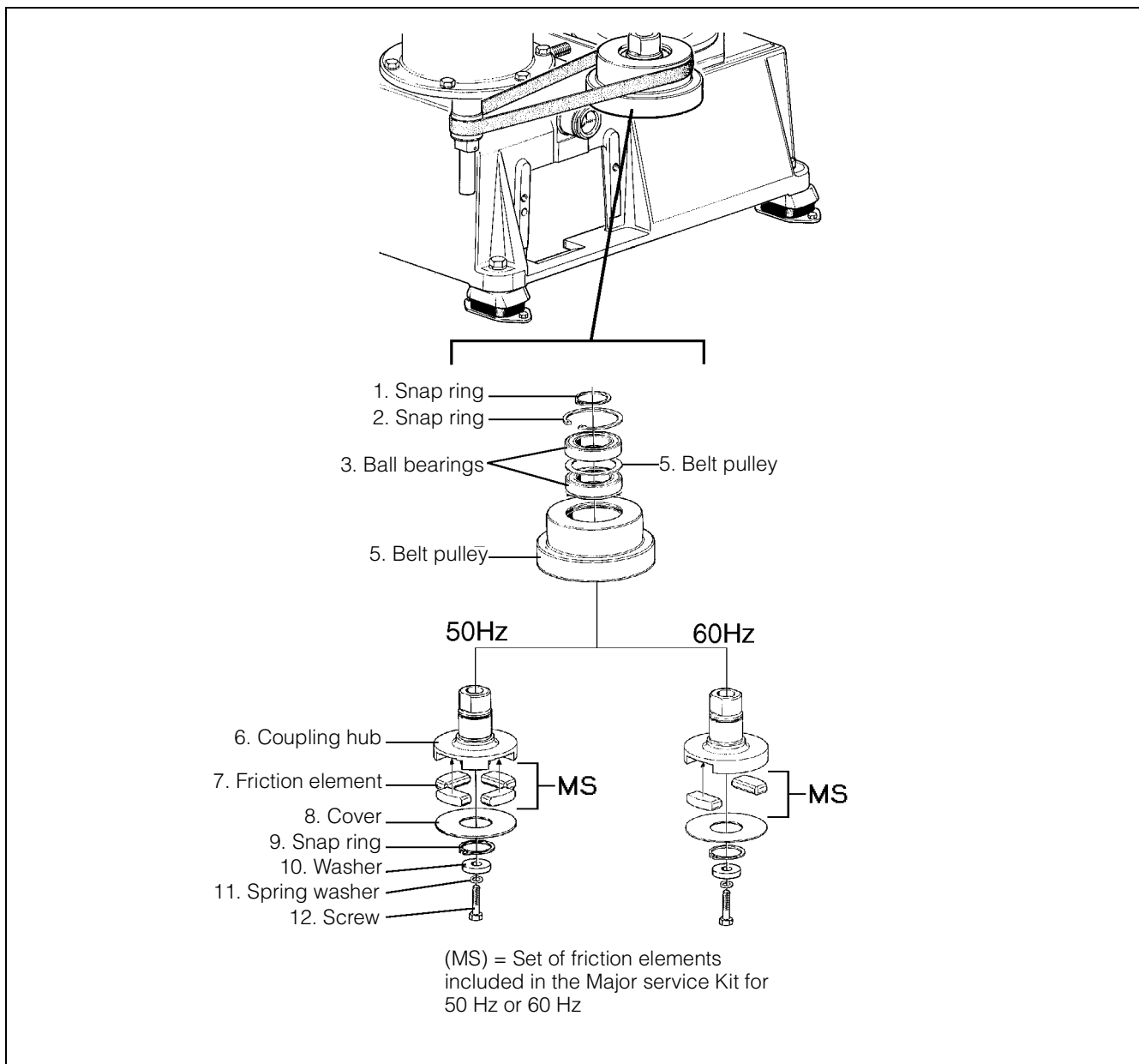

G0372121

4.3.1 Friction coupling – dismantling

- 1** Check that the belt tightener is in backward position.
- 2** Remove the motor adapter screws.
- 3** Remove the water tank and the flat belt.

Note that the tank must be lowered past spindle end (A) before it can be withdrawn (B).

- 4** Remove the flat belt.

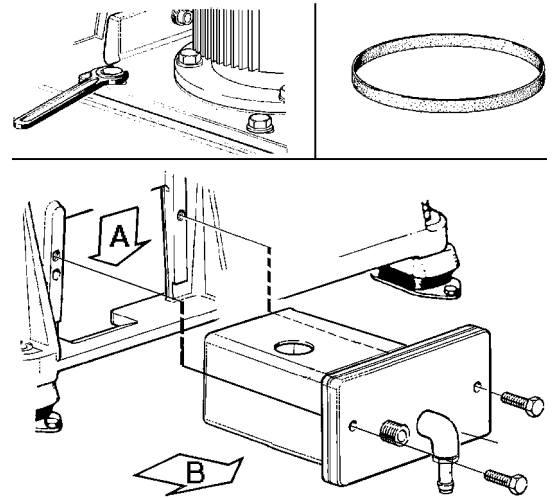

G0113391

- 5** Remove the electric motor complete with the friction coupling and motor adapter.

Weight of motor including adapter and friction coupling is not more than 35 kg.

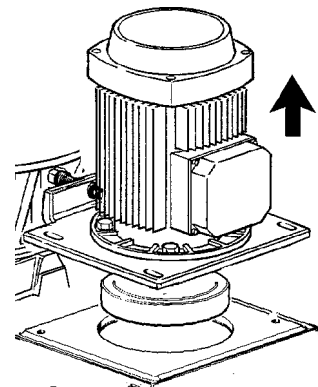

G0077331

- 6** Remove snap ring (9), cover (8) and friction elements (7).

If the friction elements are worn, fit new ones. Replace all friction elements even if only one is worn.

If the friction elements are only greasy:
Clean the friction elements and the inside of belt pulley (5) with a degreasing agent.

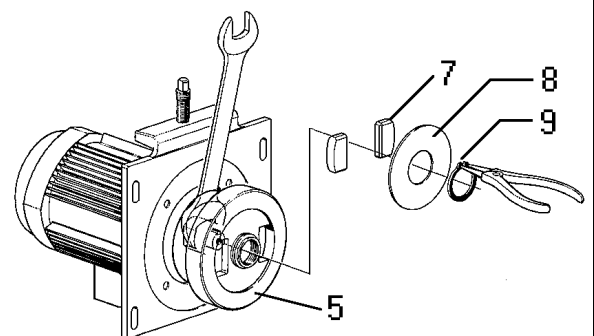

G0170841

- 7** Remove the screw (12), spring washer (11) and washer (10) from the friction coupling.

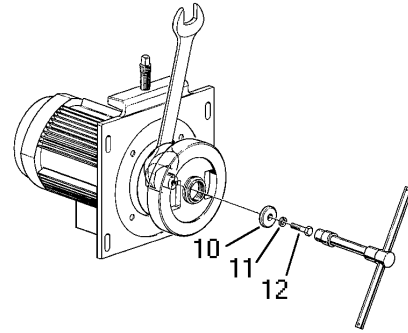

Complete dismantling of the friction coupling

- 8** Lubricate and fit the special mounting and dismantling tool.
Ease off the coupling.

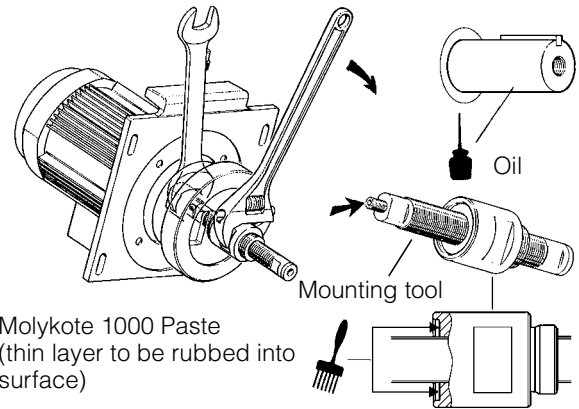

- 9** Remove snap rings (1 and 2) and drive off coupling hub (6). Turn the coupling, i.e. belt pulley (5) with bearings (3), the other way round and drive off the ball bearings and washer by using a tube.

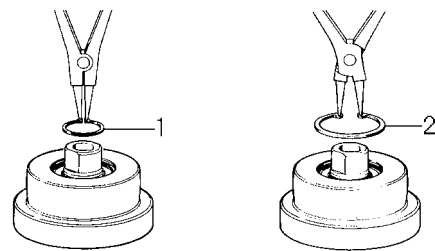

- 10** Clean all parts in a degreasing agent and replace parts supplied in the spare parts kits.

NOTE

Always discard a used bearing.

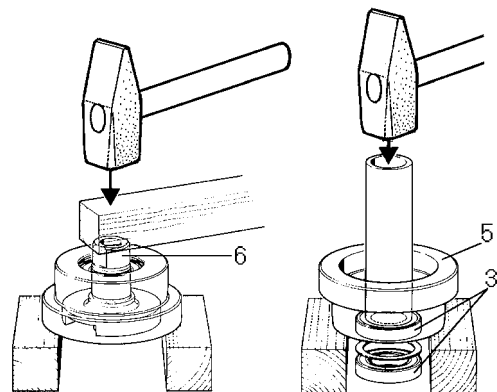

G0171021

G0171131

4.3.2 Friction coupling – assembly

Before the friction coupling is assembled, examine all parts thoroughly for wear and corrosion.

- 1** Assemble the new ball bearings in belt pulley (5) by using a tube and a hammer.

Apply Loctite 641 on the outer surfaces of ball bearings (3).

Knock down the bearings carefully (do not forget washer 4) by using the tube which must rest on the outer race of the bearing.

The new bearings must not be heated as they are packed with grease and sealed with plastic membranes.

After the assembly of the bearings, fit snap ring (2).

NOTE

Do not refit used bearings.

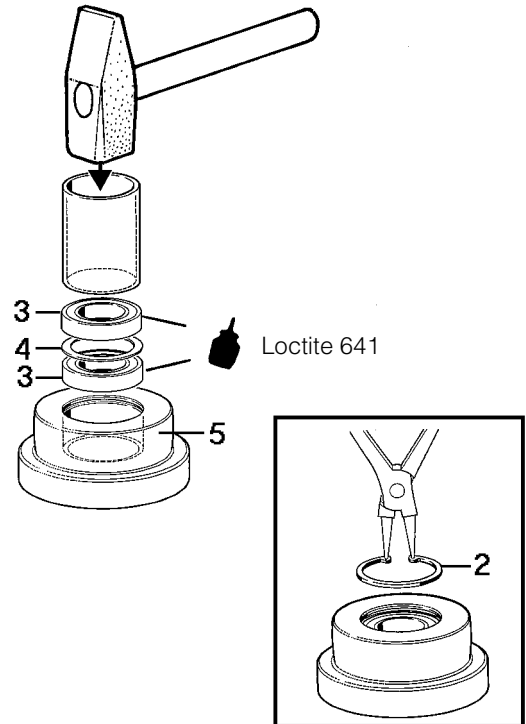

- 2** Apply Loctite 641 on the coupling hub (6) and knock it down into the belt pulley by using a hammer.
- 3** Fit snap ring (1).

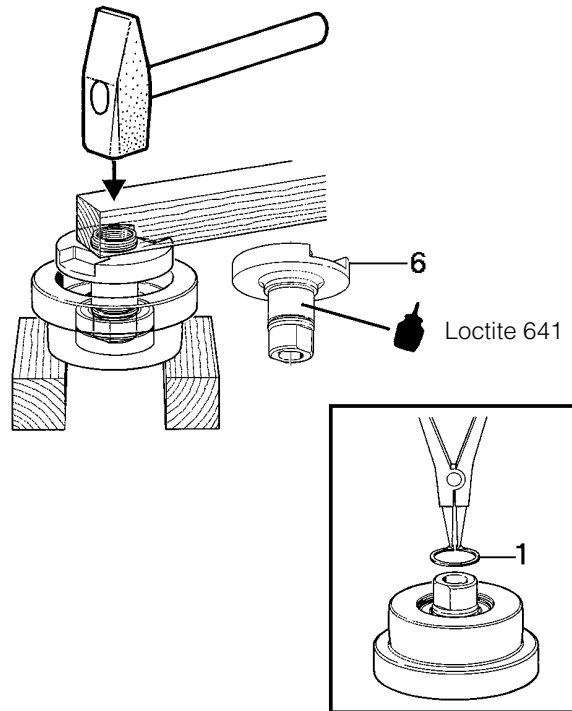

G017 1321

- 4** Wipe clean the motor shaft and apply a thin oil film on it. Fit the special mounting and dismantling tool to the motor shaft (by means of the small screw on one end of the tool) and press the friction coupling onto the shaft.

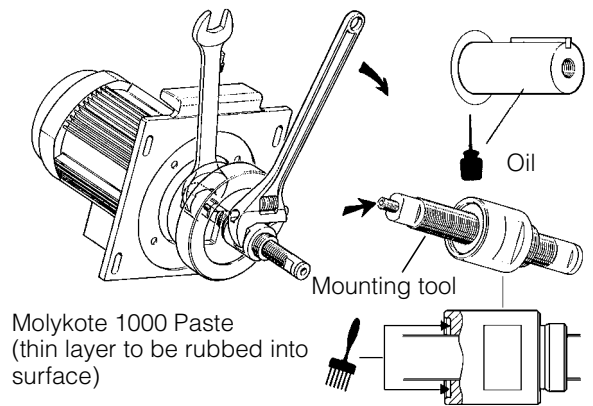

G017 1021

- 5** Fit the screw (12) with the washer (11) and spring washer (10) to secure the friction coupling.

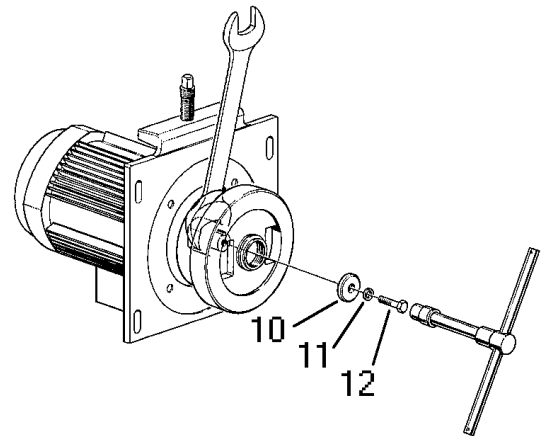

G0170921

Assembly of friction elements

- 6** Fit new friction elements (7), cover (8) and snap ring (9).
- A coupling with two friction elements is used for 60 Hz installations.
 - A coupling with four friction elements is used for 50 Hz installations.

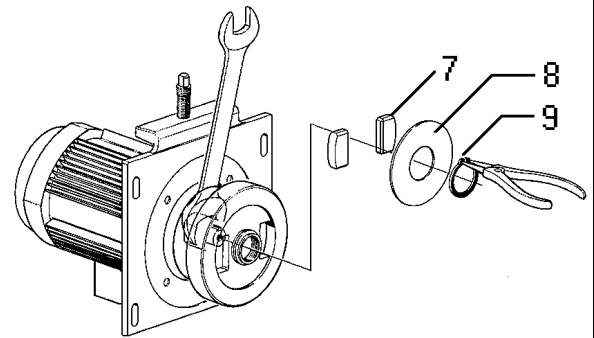

G0170831

- 7** Degrease and clean the contact surfaces of frame and motor adapter. Lubricate the contact surfaces with Molykote 1000 paste. Then fit the electric motor with adapter and friction coupling in position.

Also lubricate the threads of the belt tightener with Molykote 1000 paste or similar.

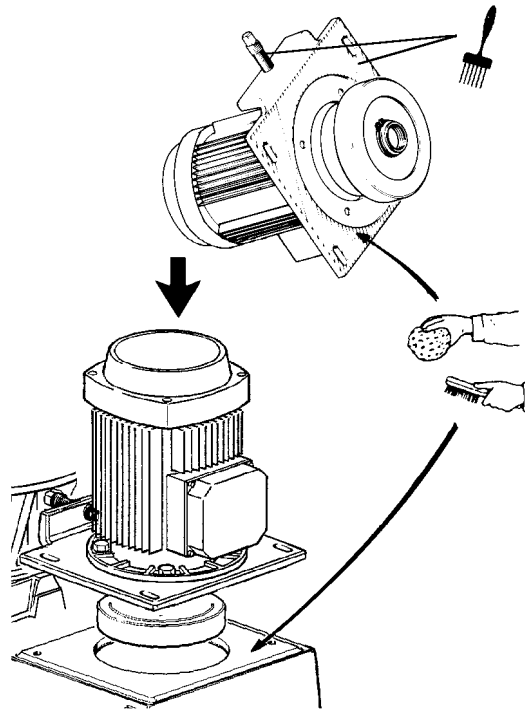

- 8** Fit and tighten the flat belt, see [4.4.1 Belt replacement and tightening, page 107](#).
- 9** Install the water tank and the cover.

NOTE

The belt must be re-tightened before starting the separator, see next page.

4.4 Flat belt and tightener

The flat belt must be removed before dismantling of the bowl spindle or the friction coupling. The procedure is the same when replacing the belt at a Major Service.

A new belt must be re-tightened **twice**:

- 30 minutes after the belt has been installed. The separator must not be started until the re-tightening has been done.
- after approximately 24 hours of operation.

NOTE

Do not start the separator unless the flat belt has been re-tightened after 30 minutes. If started, the belt may slip and be damaged.

4.4.1 Belt replacement and tightening

If only tightening of flat belt should be done, only steps **3** and **7-11** have to be performed.

WARNING

Entrapment hazards

Make sure that rotating parts have come to a complete standstill before starting any dismantling work.

Look into the slot in the frame hood to see if separator parts are rotating or not.

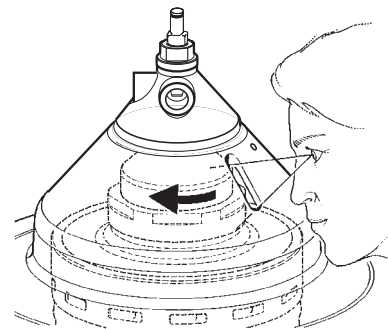

- 1 Remove the water tank and brake. Note that the tank must be lowered past spindle end (A) before it can be withdrawn (B).

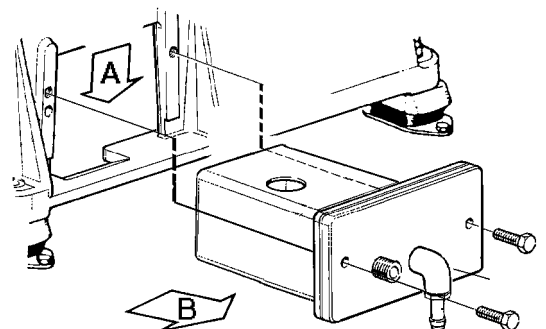

- 2** Check that the belt tightener is in backward position.

NOTE

Pay attention to the air gap "A" between the cup springs and the threaded sleeve. The distance "A" must not exceed 0,5 mm. Otherwise a correct belt tightening will be impossible.

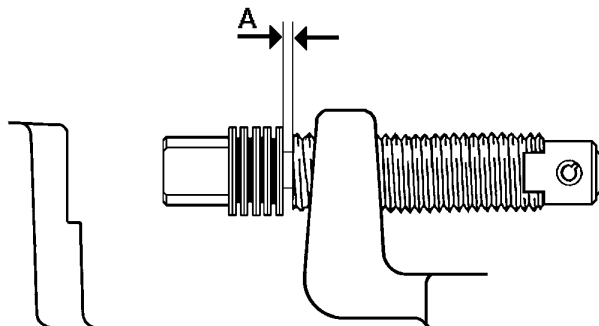

G0473911

- 3** Loosen but do not remove the motor adapter screws.

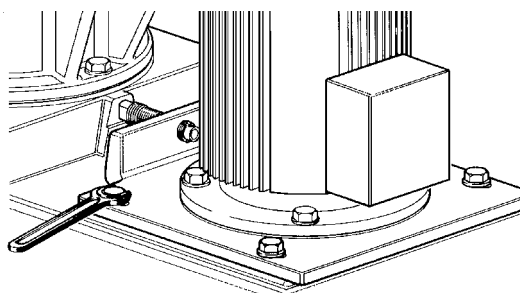

G0076622

NOTE

To guarantee a proper function of the belt tightener it is advisable to protect the surfaces

Knock out the tubular spring pin and separate the parts, lubricate and assemble the parts.

Molykote 1000 Paste

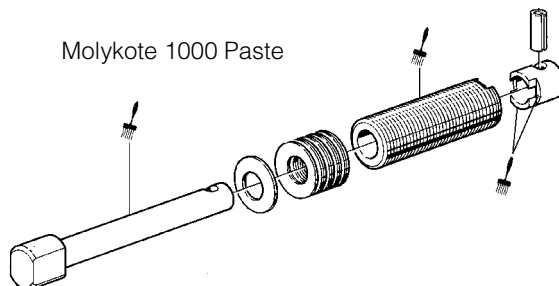

G0885711

- 4** Remove the existing belt and clean the raceways of the bowl spindle and the friction coupling by using a degreasing agent. Wipe the raceways with a clean rag after cleaning.

Exercise the greatest possible cleanliness. There must be no dirt, oil or grease on the raceways.

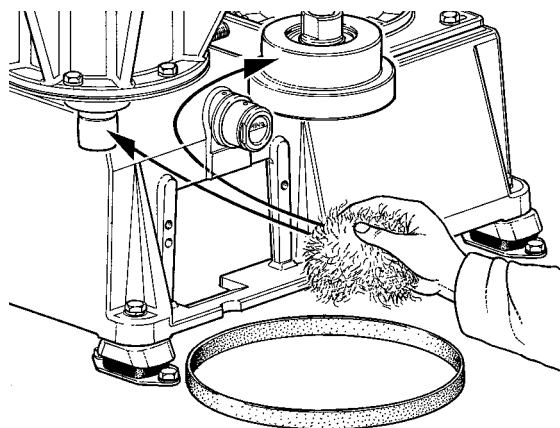

G0171531

- 5** Remove the motor adapter screws. Lift the motor together with adapter and friction coupling and check that there is a sufficient film of Molykote 1000 Paste, or an equivalent lubricating paste, between the adapter and the frame surface. Lower the motor after checking. Fit the motor adapter screws but do not tighten them.

The weight of motor including adapter and friction coupling is not more than 35 kg.

The threads of the belt tightener should be lubricated with a thin layer of Molykote 1000 Paste.
(to be rubbed into surface)

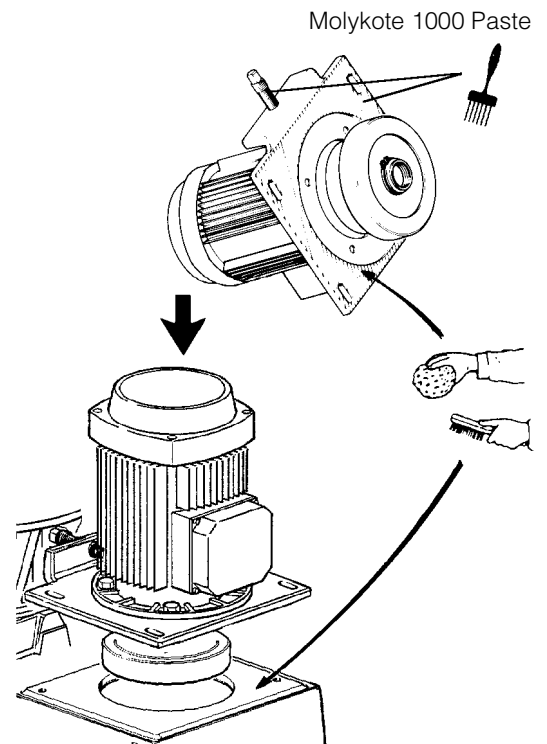

G0077341

- 6** Fit a new belt. Start on the motor side. Tighten the belt by moving the motor backwards by hand. Pull the belt around a few turns by hand.

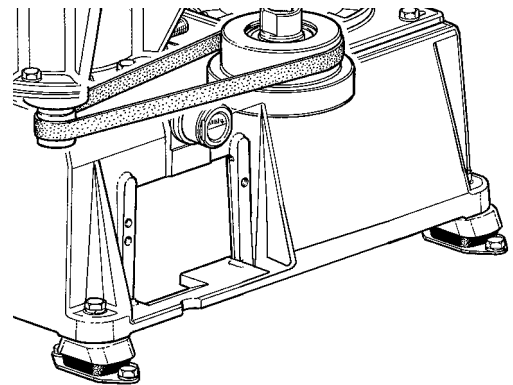

G0171661

- 7** Rotate the belt tightener by rotating the shaft until it makes contact with the frame pad.

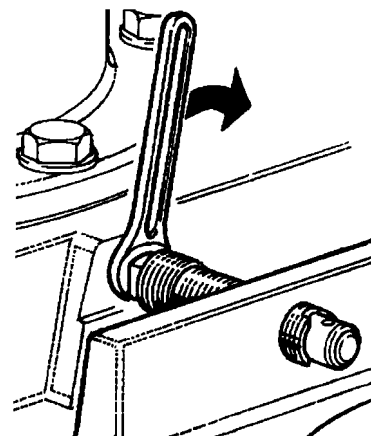

G0489821

- 8** Tighten the shaft (1) further until the threaded sleeve (2) and dog (3) are disengaged. "Shake" the motor by hand several times during this operation in order to overcome the friction between the motor adapter and the frame.

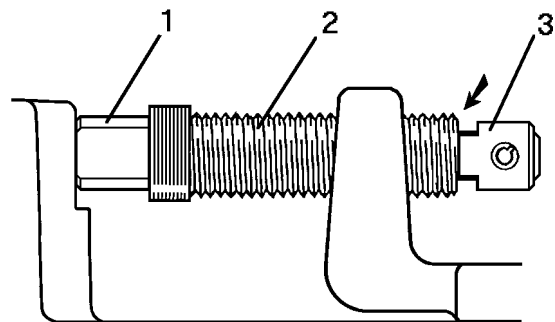
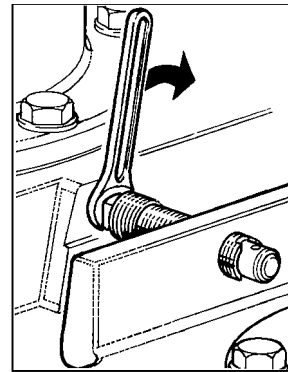

G0477111

- 9** Tighten the motor adapter screws.

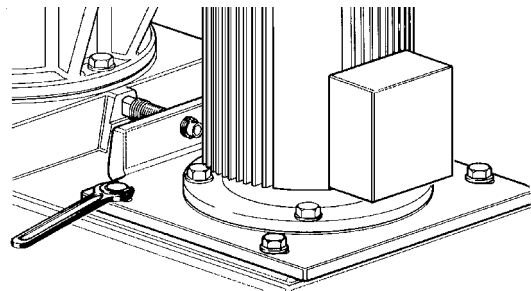

G0076622

- 10** Loosen the belt tightener by rotating the threaded sleeve (2) backwards.

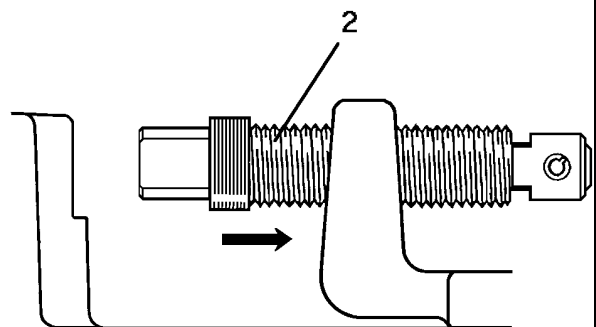

G0477211

- 11** Rotate the shaft (1) relative to the threaded sleeve (2) until the sleeve (2) and dog (3) are engaged again with a clicking sound.

NOTE

If the springs (4) are not decompressed they will lose their tension and correct tightening of belt will be impossible.

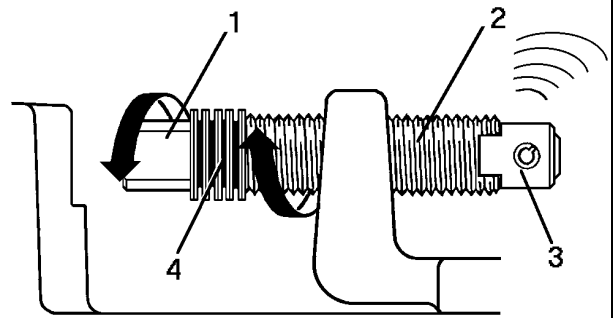

- 12** Let the belt stay in this position for at least 30 minutes without starting the separator.

Then repeat steps 3 and 7-11 above. After this proceed to step 13.

NOTE

Do not start the separator unless the flat belt has been re-tightened after 30 minutes. If started, the belt may slip and be damaged.

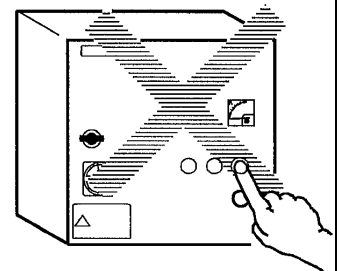
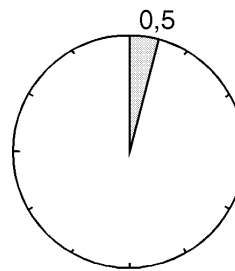

- 13** Fit the water tank and brake.

- 14** The separator may now be started.

NOTE

The belt must be re-tightened when the separator has been in operation approximately 24 hours after the belt change: Repeat steps 3 and 7-11.

4.5 Oil filling device

4.5.1 Dismantling/assembly

Drain off the oil, see [3.8 Oil change, page 56](#).

Unscrew nipple (4) and pull off the oil filling device. Then unbend the round safety wire (6) and pull off nipple (4).

- 1** If plate (8) is to be replaced, wipe the sight glass (7) with a degreasing agent.
- 2** Fit the new plate on the outside of the sight glass. The plate is self-adhesive.
- 3** Mark the position of the plate relative to the recess in sleeve (1).

Assemble the oil filling device and fit it into the frame. Note that the mark on sleeve (1) must be positioned opposite the mark on the frame. Fill the sump with new oil.

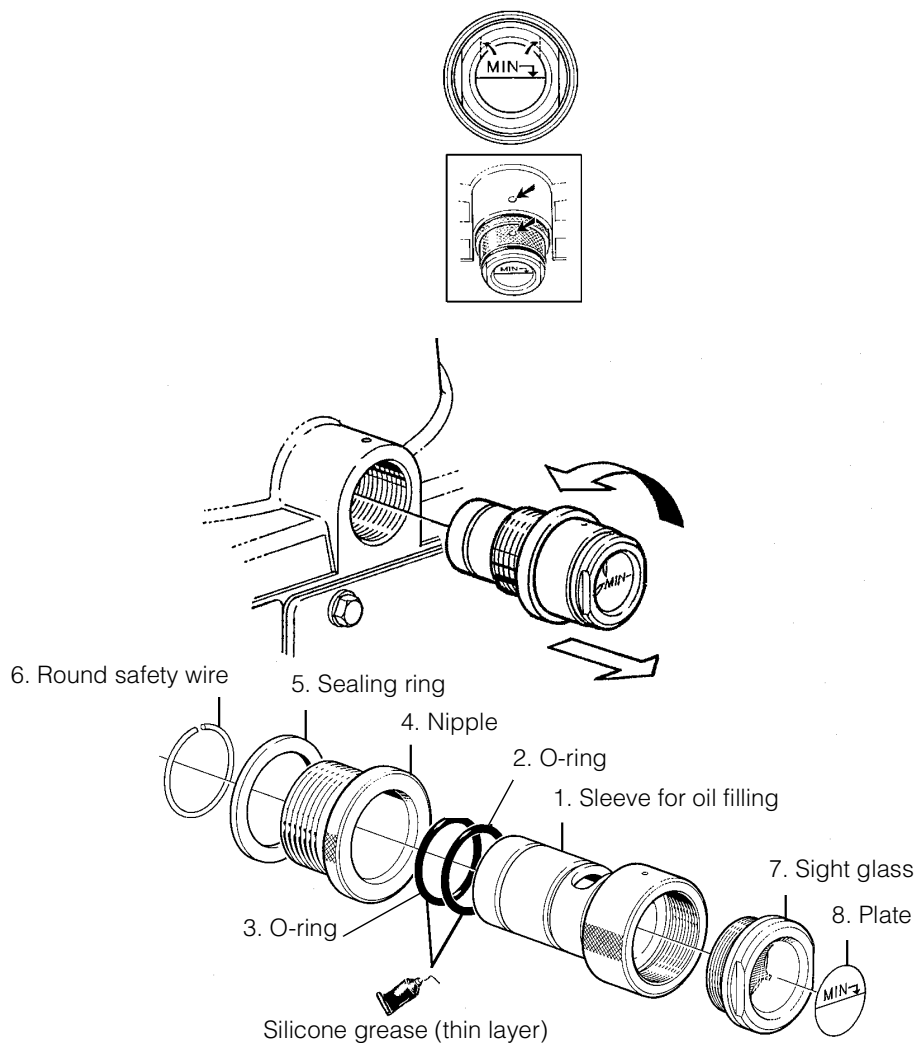

4.6 Water tank

Remove the water tank (1).

Note that the tank must be lowered past the spindle end (A) before it can be withdrawn (B).

- Check the tank interior and clean out if necessary.
- Check that the pipes are not defective. Replace if necessary.

If the parts fitted on the tank have been removed, it is necessary to fit the parts properly together at assembly.

- Seal the water inlet pipe with Loctite 573.

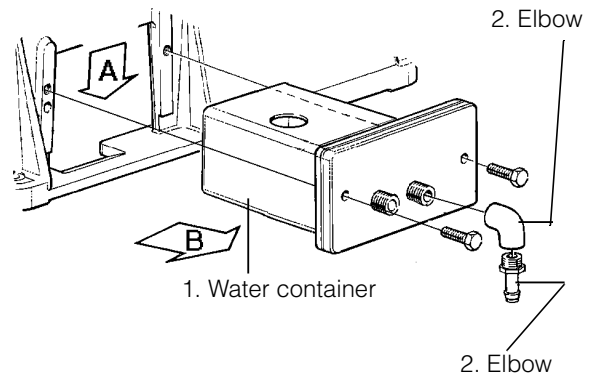

G0884711

4.7 Brake

4.7.1 Exploded view

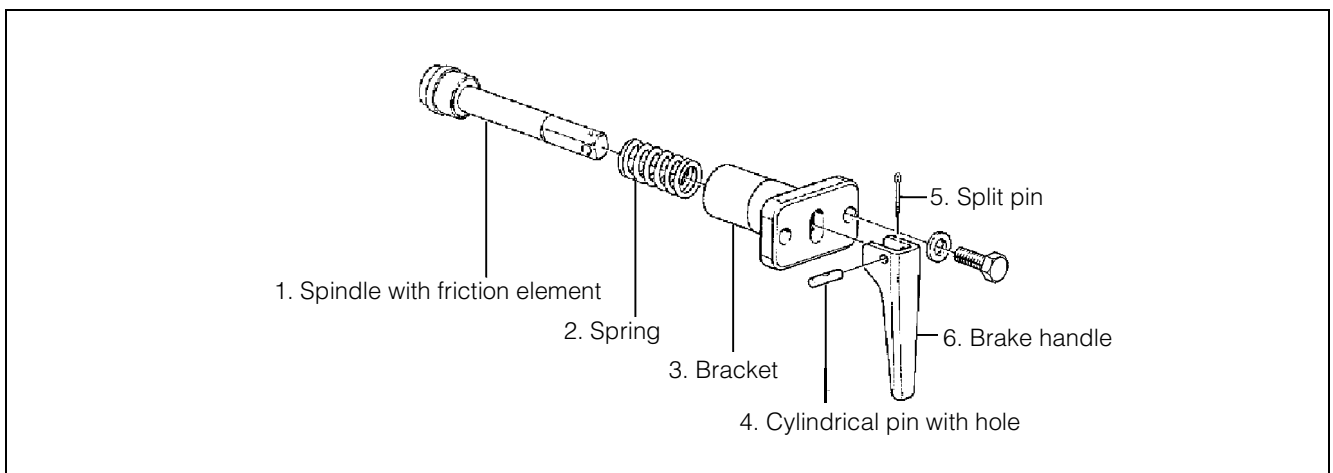

G0171731

4.7.2 Checking of friction element

A worn or oily friction element will lengthen the stopping time. Remove bracket with the brake. Examine the friction element.

- If the friction element is worn; Fit a new complete spindle (includes friction element).
- If the friction element is oily; Clean the element and its surface in contact with the belt pulley with a suitable degreasing agent.

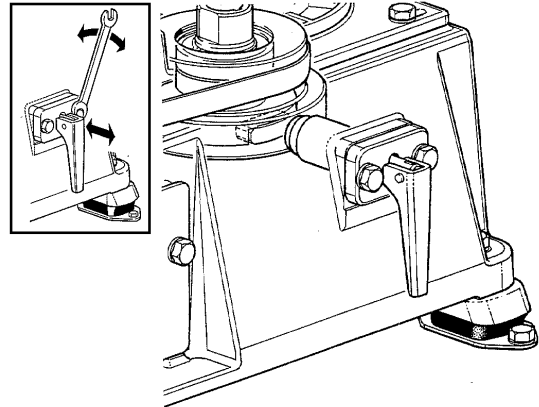

G0171821

Checking of bracket, spindle and spring

Rust can form on the brake parts and cause the brake to jam.

Remove rust from the spindle and the corresponding guide surface on the bracket. Rub the surface of the spindle with a thin layer of lubricating paste. Replace the spring with a new one if it has lost its stiffness. Oil the spring when assembling.

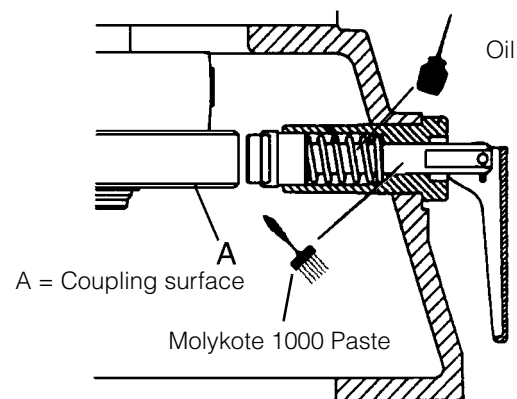

G0171931

Checking the brake

After the brake assembly has been fitted, release the brake and rotate the bowl slowly by hand. If a scraping noise is heard, the friction element is probably touching the coupling pulley surface (A). If so, it is necessary to adjust the position of the motor adapter and re-tighten the flat belt, see [4.4 Flat belt and tightener, page 107](#).

4.8 Frame feet

4.8.1 Mounting of new frame feet

When replacing the frame feet, the separator must be lifted.

Remove the bowl before lifting the separator.

Follow [3.6 Lifting instructions, page 52](#).

- 1** Loosen the foundation bolts and lift the separator.
- 2** Remove the existing frame feet.
- 3** Mount the new feet.
- 4** Place the separator in its original position and fasten the foundation bolts.
- 5** Remove the two lifting eye bolts.
- 6** Assemble the separator bowl, see [4.1.2 Inlet/outlet and bowl - assembly, page 76](#).

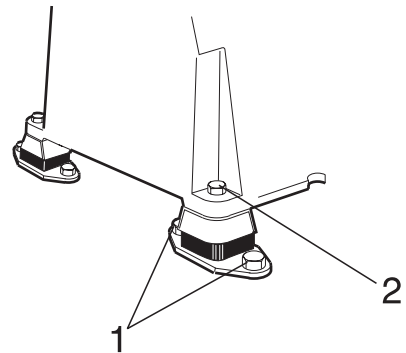

5 Technical Reference

Contents

5.1 Product description	118	5.8.6 Operating water interface (Clarifier)	147
5.2 Technical data	119	5.8.7 Performance data, in- and outlet device	148
5.3 Connection list	120	5.8.8 Interconnection diagram	150
5.4 Basic size drawing	122	5.9 Storage and installation	151
5.4.1 Dimensions of connections	123	5.9.1 Introduction	151
5.5 Interface description	124	5.10 Protection and storage of goods	152
5.5.1 Scope	124	5.10.1 Storage at out of operation	153
5.5.2 References	124	5.10.2 Before start-up	153
5.5.3 Definitions	124	5.10.3 Connections to surrounding equipment	154
5.5.4 Goal	125	5.10.4 Reassembly and Start up	155
5.5.5 Description of separator modes.	126	5.10.5 Storage and transport of goods	155
5.5.6 Handling of connection interfaces.	127	5.10.6 Planning of installation	158
5.5.7 Fluid connections.	128	5.10.7 Foundations	160
5.6 Water quality	132		
5.7 Lubricants	133		
5.7.1 Lubrication chart.	133		
5.7.2 Alfa Laval lubricating oil groups	134		
5.7.3 Recommended lubricants	135		
5.7.4 Recommended lubricating oils	137		
5.7.5 Recommended oil brands	138		
5.8 Drawings	140		
5.8.1 Foundation plan	140		
5.8.2 Gravity disc nomogram	141		
5.8.3 Electric motor	142		
5.8.4 Machine plates and safety labels	144		
5.8.5 Operating water interface (Purifier)	146		

5.1 Product description

Alfa Laval ref. 570871, rev. 0

Product number: 881099-06-02/0

Separator type: P 605

Application: Mineral oil

Technical design:

Purifier (clarifier as option) with partial discharge.

Machine bottom part for belt drive

Intended for marine and land applications.

Colour of finish painting of painted parts according to order.

Quality of painting according to specifications on drawings.

Sealings available in Nitrile.

Designed in accordance with directives and standards:

98/37/EC 91/368 EEC 93/44 EEC	Directive of the European Parliament and the Council relating to machinery.
ISO 3744	Acoustics - determination of sound power levels of noise sources using sound pressure.
EN 292-2	Safety of machines. Use of the machine in applications subject to hygienic demands require a well adapted cleaning program.

Operational limits:

Max. Allowed speed 9510 r/minute

Discharge interwall: 2 - 60 minutes

Feed temperature: 0 °C to + 100 °C

Ambient temperature: + 5 °C to + 55 °C

Not to be used for liquids with flashpoint below 60 °C

Maximum allowed density of operating liquid: 1000 kg/m³

5.2 Technical data

Alfa Laval ref. 561687, rev. 1,

Maximum density	feed sediment	1100 kg/m ³ 2631 kg/m ³
Power consumption	idling running (at max. capacity) max. power consumption	0,8 kW 1,8 kW 2,8 kW (at starting-up)
Bowl speed	9510/9305	max. rev/min. 50Hz/60Hz
Speed motor shaft	3000/3600	max. rev/min. 50Hz/60Hz
Gear ratio (pulleys)	130:41 (50 Hz) 106:41 (60 Hz)	
Starting time	1,8 - 2,3 minutes	
Stopping time	Running down without brake With brake	average 14 minutes min. 3, max. 4 minutes
Maximum running time without flow	Empty bowl Filled bowl	180 minutes 180 minutes
Sludge volume total/efficient	0,6 / 0,2 litres	
Bowl volume	1,5 litre	
Discharge volume	1 litre (nominal) fixed	
Required water quality	See 5.6 Water quality, page 132	
Lubrication	See 5.7 Lubricants, page 133	
Lubricating oil volume	0,5 litre	
Sound pressure level	69 dB(A)	
Vibration level	New separator Separator in use	Max. 5,6 mm/sec Max. 9 mm/sec
Weight	Separator without motor Motor Complete bowl Overhead hoist for 300 kp is required	Net weight approx. 191 kg 16 kg 35 kg
Motor power	2,2 Kw	
Bowl material	AL 111 2377-02	stainless steel

NOTE

The separator is a component operating in an integrated system including a monitoring system. If the technical data in the system description does not agree with the technical data in this instruction manual, the data in the system description is the valid one.

5.3 Connection list

Alfa Laval ref. 561658, rev. 1

Connection No.	Description	Requirements/limits
201	Inlet for process liquid. - Flow: - Pressure:	See 5.8.7 Performance data, in- and outlet device, page 148
206	Inlet for liquid seal and displacement liquid. - Quality requirements: - Flow, set value:	See 5.6 Water quality, page 132 8 litres/minute
220	Outlet for light phase, clarified liquid. - Counter pressure: - Capacity:	See 5.8.7 Performance data, in- and outlet device, page 148
(221)	Outlet for heavy phase (water).	Should be possible to drain liquids by gravity.
222	Outlet for solid phase. - Discharge volume:	See 5.2 Technical data, page 119 The outlet after the separator should be installed in such a way that you can not fill the frame top part with sludge. (Guidance of sludge pump or open outlet)
372	Inlet for discharge liquid. - Flow , set value: - Quality requirements:	18 litres/minute See 5.6 Water quality, page 132

Connection No.	Description	Requirements/limits
373	Inlet for make-up liquid. - Flow, set value: - Quality requirements: - Consumption:	0,9 litres per minute See 5.6 Water quality, page 132 0,9 litres per discharge
377	Outlet for operating liquid.	Should be possible to drain liquids by gravity.
462	Drain of frame top part, lower.	Should be possible to drain liquids by gravity.
463	Drain of frame top part, upper.	Should be possible to drain liquids by gravity.
701	Motor for separator Allowed deviation from nominal frequency (momentarily during maximum 5 seconds):	$\pm 5\%$ ($\pm 10\%$)
753	Unbalance sensors, vibration - Type: - Frequency range: - Vibration measurement range: - Internal impedance: - Reset coil voltage: - Reset coil power: - Switch rating, resistive load max	Mechanical switch < 300 Hz < 4,5 g 4 k Ω \pm 5% 48 V DC Max. 14 W 2 A @ 24 V DC

Location of connections on the separator, see [5.4 Basic size drawing, page 122](#), and [5.4.1 Dimensions of connections, page 123](#).

5.4 Basic size drawing

Alfa Laval ref. 565297, rev. 1

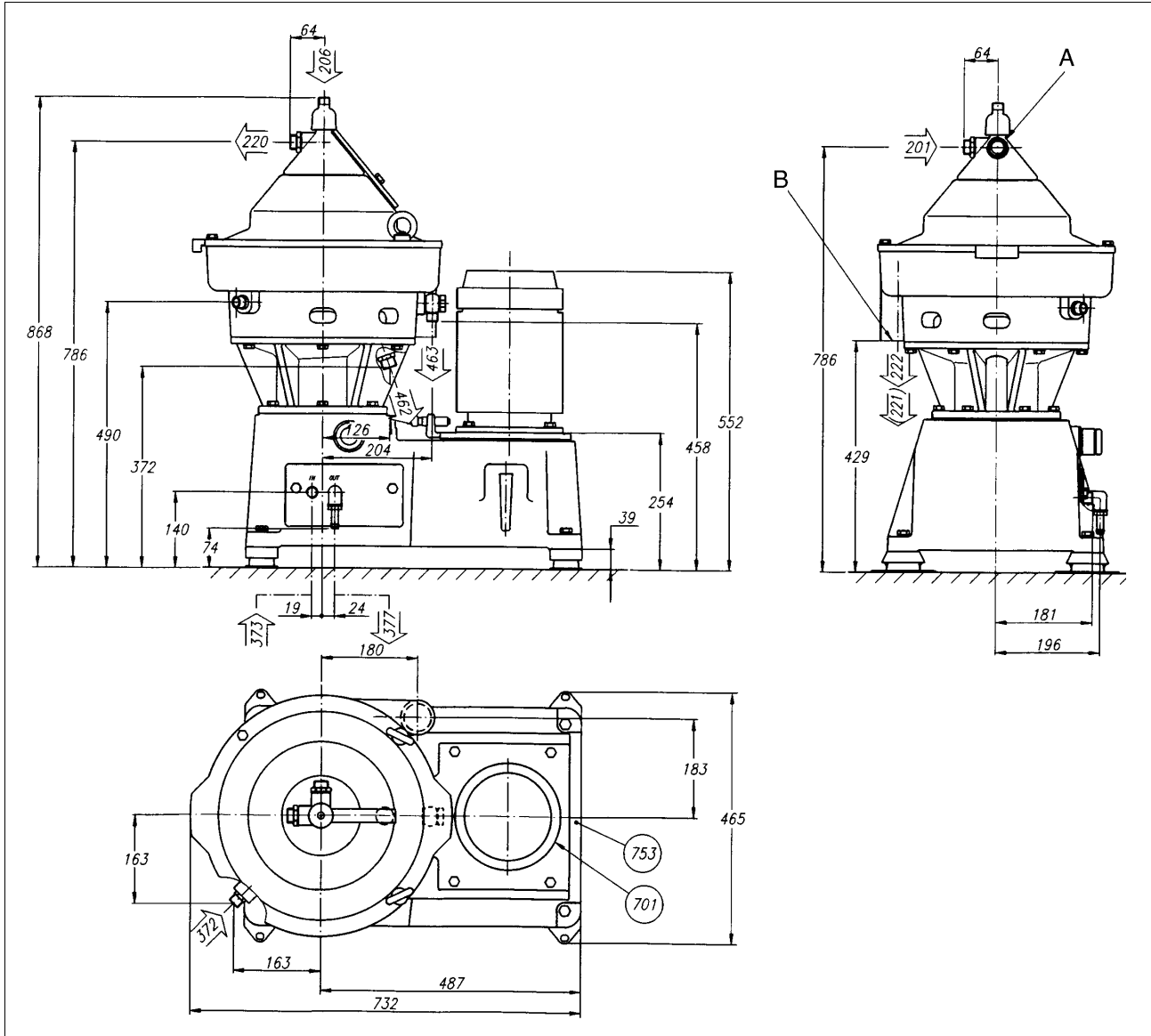

Connections 201 and 220 are turnable 90°.
A Maximum horizontal displacement during operation ±20 mm
B Maximum vertical displacement during operation ±10 mm

G0922911

5.4.1 Dimensions of connections

Alfa Laval ref. 565297 rev. 1

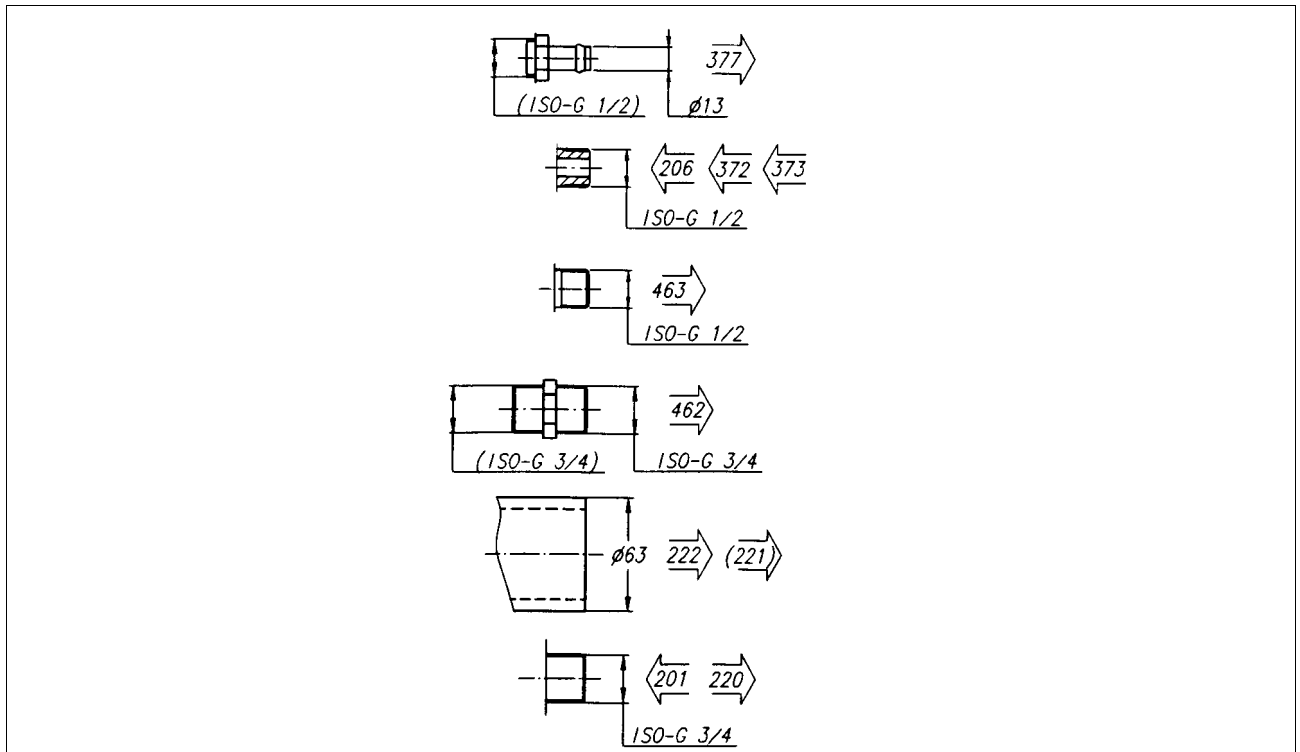

All dimensions are nominal.
 Reservation for individual deviations due to tolerance.
 All connections to be installed non-loaded and flexible.
 Data for connections see [5.3 Connection list, page 120](#)

G0922921

5.5 Interface description

Alfa Laval ref. 565810, rev. 0

5.5.1 Scope

This document gives information, requirements and recommendations about operational procedures and signal processing for safe and reliable operation of the separator. It is intended to for designing auxiliary equipment and control system for the separator.

5.5.2 References

This *Interface Description* is one complementary document to the separator. Other such documents that contain necessary information and are referred to here are:

- Interconnection diagram
- Connection List
- Technical Data
- Operating Water Interface

Standards referred to are:

- EN 418 Safety of machinery - Emergency stop equipment, functional aspects - Principles of design
- EN 1037 Safety of machinery - Prevention of unexpected start-up

5.5.3 Definitions

For the purpose of this document, the following definitions apply:

- Synchronous speed: The speed the machine will attain when it is driven by a three-phase squirrel-cage induction motor and there is no slip in the motor and the drive system.
- Full speed: The synchronous speed minus normal slip.

5.5.4 Goal

To eliminate situations that can cause harm, i.e. injury, damage to health or property and unsatisfactory process result are e.g.:

Situation	Effect
Unbalance caused by uneven sediment accumulation in the bowl.	Too high stress on bowl and bearing system which might cause harm.
Too high bowl speed.	Too high stress on bowl which might cause harm.
Access to moving parts.	Can cause injury to person who accidentally touches these parts.
Insufficient cleaning of separator.	Unsatisfactory product quality.
Bowl leakage.	Product losses.

Information and instructions given in this document aim at preventing these situations.

Control and supervision can be more or less comprehensive depending on the type of used control equipment. When a simple control unit is used it would be impossible or too expensive to include many of the functions specified here while these functions could be included at nearly no extra cost when a more advanced control unit is used. For this reasons functions that are indispensable or needed for safety reasons to protect the machine and/or personnel are denoted with *shall* while other functions are denoted with *should*.

5.5.5 Description of separator modes.

For control purposes the operation of the separator should be divided into different modes.

The normally used modes are described below but other modes might exist.

It is assumed that:

- The separator is correctly assembled.
- All connections are made according to “Connection List”, “Interconnection Diagram” and “Interface Description”.
- The separator control system is activated.

If above conditions are not fulfilled the separator is unready for operation.

STAND STILL means:

- The power to the separator motor is off.
- The bowl is not rotating.

STARTING means:

- The power to the separator motor is on.
- The bowl is rotating and accelerating.

RUNNING means:

- The power to the separator motor is on.
- The bowl is rotating at full speed.

RUNNING is a collective denomination for a

number of sub modes which e.g. can be:

- *STAND BY*: Separator is in a waiting mode and not producing.
- *PRODUCTION*: Separator is fed with product and producing.
- *CLEANING*: Separator is fed with cleaning liquids with the intention to clean the separator.

STOPPING means:

- The power to the separator motor is off.
- The bowl is rotating and decelerating.

STOPPING is a collective denomination for a number of sub modes which e.g. can be:

- *NORMAL STOP*: A manually or automatically initiated stop.
- *SAFETY STOP*: An automatically initiated stop triggered by too high vibrations.
- *EMERGENCY STOP*: A manually initiated stop at emergency situations. This stop will be in effect until it is manually reset.

5.5.6 Handling of connection interfaces.

Electrical connections.

701 Separator motor.

The separator is equipped with a 3-phase DOL (Direct On Line) started motor.

There shall be an emergency stop circuit designed according to EN 418 and a power isolation device according to EN 1037.

There shall be a start button close to the separator that shall be used for first start after assembly of the separator.

There should be a counter to count number of running hours.

There should be a current transformer to give an analogue signal to the control unit about the motor current.

753 Unbalance sensor.

For indication of any abnormal unbalance and to be able to perform appropriate countermeasures, the separator may be equipped with a vibration initiated mechanical switch on the separator frame.

The vibration monitor shall include a self-check function to be performed at least at initiation of *STARTING*.

If to high vibrations occur the separator shall be stopped the quickest way possible and it shall not be restarted until the reasons for the vibrations have been found and measures to remove them have been taken.

Signal processing in *STARTING*:

- If to high vibrations occur the separator shall be stopped automatically by *SAFETY STOP*.
- If the self-check system triggers, an alarm shall be given and an automatic stop by *NORMAL STOP* shall be initiated.

Signal processing in *RUNNING*:

- If to high vibrations occur the separator shall be stopped automatically by *SAFETY STOP*.
- If the self-check system triggers, an alarm shall be given.

Signal processing in *STOPPING*:

- If the self-check system triggers, an alarm shall be given.

Signal processing in *NORMAL STOP*:

- If to high vibrations occur the system shall turn over automatically to *SAFETY STOP*.

5.5.7 Fluid connections.

Complementary information is given in [5.3 Connection list, page 120](#).

201 Inlet for process liquids (feed).

Processing in *STAND STILL*:

- Shall be closed.

Processing in *STARTING*:

- Should be closed. Bowl will be open and empty or closed and filled depending on if start is done from *STAND STILL* or *STOPPING*.

Processing in *RUNNING*:

- Could be closed or open.
- Shall be closed before a discharge. See [5.8.5 Operating water interface \(Purifier\), page 146](#) or [5.8.6 Operating water interface \(Clarifier\), page 147](#).

Processing in *NORMAL STOP* or *EMERGENCY STOP*:

- Could be closed or open but the bowl should be filled unless the stop is initiated in *STARTING*.

Processing in *SAFETY STOP*:

- Could be closed or open but the bowl shall be filled unless the stop is initiated in *STARTING*.

206 Inlet to liquid seal.

Processing in *STAND STILL*:

- Shall be closed.

Processing in *STARTING*:

- Shall be closed.

Processing in *RUNNING*:

- Supplying a liquid seal prior to opening the feed: See [5.8.5 Operating water interface \(Purifier\), page 146](#) or [5.8.6 Operating water interface \(Clarifier\), page 147](#).
- Displacing (the interface) before a discharge: See [5.8.5 Operating water interface \(Purifier\), page 146](#) or [5.8.6 Operating water interface \(Clarifier\), page 147](#).

220 and 221 Outlets

Processing in *STAND STILL*:

- Could be closed or open.

Processing in other modes:

- Shall be open.

372 Inlet for discharge liquid.

Processing in *STAND STILL*:

- Shall be closed.

Processing in *STARTING*:

- Shall be closed.

Processing in *RUNNING*:

- A discharge is initiated according to procedure in "Operating Water Interface".
- After a discharge has been triggered the motor current or bowl speed should be monitored to indicate if there comes a current peak or a sudden drop in speed. The absence of such a signal indicates that the discharge has failed and corrective action should be taken (e.g. trigger a new discharge). Absence of a discharge may result in problems due to solidification of the sediment.
That the current returns to original value after discharge could also be supervised. If current is much higher after the discharge this might be an indication that the bowl has not closed properly after the discharge.
- For service purposes there should be a counter to count number of discharges.

373 Inlet for make-up liquid.

Processing in *STAND STILL*:

- Shall be closed.

Processing in *STARTING*:

- Shall be closed.

Processing in *RUNNING*:

- The separator bowl is closed according to procedure in “Operating Water Interface”.
- The separator bowl is closed in a discharge sequence according to procedure in “Operating Water Interface”.

5.6 Water quality

Alfa Laval ref. 553406, rev. 5

Quality requirements for operating water

Operating water is used in the separator for several different functions: e.g. to operate the discharge mechanism, to lubricate and cool mechanical seals, etc. Poor quality of the operating water may with time cause erosion, corrosion and/or operating problem in the separator and must therefore be treated to meet certain demands.

The following requirements are of fundamental importance

- 1** Turbidity-free water, solids content <0,001% by volume. Deposits must not be allowed to form in certain areas in the separator.
- 2** Max particle size 50 µm.
- 3** Total hardness less than 180 mg CaCO₃ per litre, which corresponds to 10 °dH or 12,5 °E. Hard water may with time form deposits in the operating mechanism. The precipitation rate is accelerated with increased operating temperature and low discharge frequency. These effects become more severe the harder the water is.
- 4** Chloride content max 100 ppm NaCl (equivalent to 60 mg Cl/l). Chloride ions contribute to corrosion on the separator surfaces in contact with the operating water, including the spindle. Corrosion is a process that is accelerated by increased separating temperature, low pH, and high chloride ion concentration. A chloride concentration above 60 mg/l is not recommended.
- 5** pH>6
Increased acidity (lower pH) increases the risk for corrosion; this is accelerated by increased temperature and high chloride ion content.

NOTE

Alfa Laval accepts no liability for consequences arising from unsatisfactorily purified operating water supplied by the customer

5.7 Lubricants

Alfa Laval ref. 553216-01 rev. 6

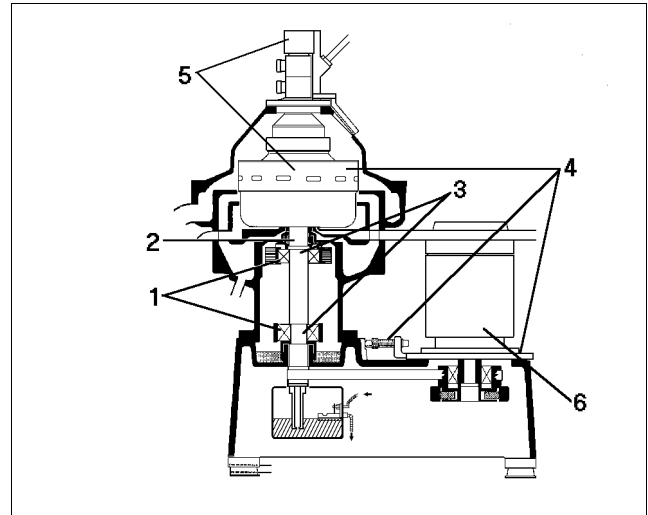

G0112122

5.7.1 Lubrication chart.

	Lubricating points	Lubricants
1	Bowl spindle ball bearings and buffers are lubricated by oil mist.	Lubricating oil as specified in 5.7.5 Recommended oil brands, page 138.
2	Bowl spindle taper.	Lubricating oil, only a few drops for rust protection.
3	Metal buffers of bowl spindle.	Lubricating oil.
4	Bowl: Sliding contact surfaces and pressure-loaded surfaces such as lock rings, threads of lock rings, bowl hood and cap nut.	Pastes as specified in 5.7.3 Recommended lubricants, page 135.
5	Rubber seal rings.	Grease as specified in 5.7.3 Recommended lubricants, page 135.
6	Friction coupling ball bearings.	The bearings are packed with grease and sealed, they need no extra lubrication.
7	Electric motor.	Follow the manufacturer's instructions.

5.7.2 Alfa Laval lubricating oil groups

Alfa Laval ref. 553216-01 rev. 6

- **Group A oil:** a high quality gear oil on paraffin base with stable AW (anti wear) additives.
- **Group B oil:** a high quality gear oil on paraffin base with stable EP (extreme pressure) additives.
- **Group D oil:** a synthetic base oil with additives stable at high operating temperatures.
- **Group E oil:** Characteristics as a group D-oil but suitable at a higher operation power (≤ 55 kW)

Do not mix different oil brands or oils from different oil groups.

Always use clean vessels when handling lubricating oil.

Great attention must be paid not to contaminate the lubricating oil. Of particular importance is to avoid mixing of different types of oil. Even a few drops of motor oil mixed into a synthetic oil may result in severe foaming.

Any presence of black deposits in a mineral type oil is an indication that the oil base has deteriorated seriously or that some of the oil additives have precipitated. Always investigate why black deposits occurs.

If it is necessary to change from one group of oil brand to another it is recommended to do this in connection with an overhaul of the separator. Clean the gear housing and the spindle parts thoroughly and remove all deposits before filling the new oil.

**NOTE**

Always clean and dry parts (also tools) before lubricants are applied.

**CAUTION**

Check the oil level before start. Top up when necessary.
Oil volume = see **5.2 Technical data, page 119.**

It is of utmost importance to use the lubricants recommended in our documentation.

This does not exclude, however, the use of other brands, provided they have equivalently high quality properties as the brands recommended. The use of oilbrands and other lubricants than recommended, is done on the exclusive responsibility of the user or oil supplier.

Applying, handling and storing of lubricants

Always be sure to follow lubricants manufacturer's instructions.

5.7.3 Recommended lubricants

Alfa Laval ref. 553217-01 rev. 8

Pastes for non-food applications:

NOTE

The data in below tables is based on supplier information in regards to lubrication properties. Trade names and designations might vary from country to country, contact your local supplier for more information.

Brands with Alfa Laval article numbers are approved and recommended for use.

Manufacturer	Designation	Alfa Laval No.
Fuchs Lubritech	Gleitmo 805 K Gleitmo 705 K	
Dow Corning	Molykote 1000 (Paste) Molykote 1000 (Paste) Molykote G-rapid plus (Paste)	537086-02(1000 g) 537086-03 (100 g) 537086-04 (50 g)
Rocol	Antiscuffing (ASP) (Paste)	
Kluber	Wolfracoat C (Paste)	

Bonded coatings

Manufacturer	Designation	Alfa Laval No.
Fuchs Lubritech	Gleitmo 900 (Varnish or spray)	
Dow Corning	Molykote D321R (Spray) Molykote D321R (Varnish)	535586-01 (300 ml) 535586-02 (60 ml)

Silicone grease for rubber rings

Manufacturer	Designation	Alfa Laval No.
Dow Corning	Molykote 111 (Compound) Molykote 111 (Compound)	539474-02 (100 g) 539474-03 (25 g)
Fuchs Lubritech	Gleitmo 750	
Kluber	Unisilikon L 250 L	
Wacker	Silicone P (Paste)	

Greases for ball and roller bearings:**NOTE**

Always follow the specific recommendation for lubrication as advised by the manufacturer.

Manufacturer	Designation
BP	Energrease MM-EP2 Energrease LS2
Castrol	APS 2 Grease EPL 2
Chevron	Duralith grease EP2
Elf	Epexa 2
Esso/Exxon	Beacon EP2 Unirex N2
Fina	Marson EPL 2A
Mobil	Mobilith SHC 460 Mobilux EP2
Gulf	Gulflex MP2
Q8/Kuwait Petroleum	Rembrandt EP2
Shell	Albida Grease EP2 Alvania EP Grease 2
SKF	LGEP2 or LGMT2
Texaco	Multifak AFB 2

5.7.4 Recommended lubricating oils

Alfa Laval ref. 553219-09 rev. 0

Two different groups of lubricating oils are approved. They are designated as Alfa Laval lubricating oil groups A and D which are described in [5.7.2 Alfa Laval lubricating oil groups, page 134](#).

The numerical value after the letter in the table states the viscosity grade..

Ambient temperature	Alfa Laval lubricating oil group	Time in operation Oil change interval
between +15 and +45 °C	A/150	1500 h
between +2 and +65 °C	D/220	2000 h

The corresponding commercial oil brands are listed on next page.

NOTE

- When the separator is operated for short periods, lubricating oil must be changed every 12 months even if the total number of operating hours is less than stated in the recommendations above.
- Check and prelubricate spindle bearings on separators which have been out of service for 6 months or longer.
- In seasonal operation: change oil before every operating period.

Alfa Laval do not accept responsibility for any damage caused by the use of lubricants which deviate from the recommended lubricants listed in this manual.

5.7.5 Recommended oil brands

Alfa Laval lubricating oil group A/150

Alfa Laval ref. 553218-04 rev. 2

NOTE

The data in below tables is based on supplier information in regards to lubrication properties. Trade names and designations might vary from country to country, contact your local supplier for more information.
Brands with Alfa Laval article number are approved and recommended for use.

Alfa Laval lubrication oil group A	
Viscosity grade VG (ISO 3448/3104)	150
Viscosity index VI (ISO 2909)	>95
Manufacturer	Designation
Alfa Laval	546098-80(20 litres) 546098-81(4 litres) 546098-82(208 litres) 546098-83(1 litre)
BP	Bartran 150
Castrol	Alpha ZN 150
Esso/Exxon	Nuto 10 Teresso 150 Terrestic 150
Mobil	DTE oil Extra Heavy
Q8/Kuwait Petroleum	Haydn 150
Shell	Morlina 150 Tellus 150
Texaco/Caltex	Regal Oil 150 Paper Machine Oil Premium 150

Alfa Laval lubricating oil group D/220

Alfa Laval ref. 553218-08 rev. 3

Specification: Synthetic lubricating oil,
category PAO (ISO-L-) CKE 220

NOTE

The data in below tables is based on supplier information in regards to lubrication properties. Trade names and designations might vary from country to country, contact your local supplier for more information.
Brands with Alfa Laval article number are approved and recommended for use.

Alfa Laval lubrication oil group D	
Viscosity grade VG (ISO 3448/3104)	220
Manufacturer	Designation
Alfa Laval	542690-80(20 litres) 542690-81(4 litres) 542690-82(208 litres)
BP	Enersyn HTX 220
Castrol	Alphasyn EP 220 Alphasyn HG 220
Chevron	Tegra 220
ELF	Epona SA 220
Esso/Exxon	Terrestic SHP 220 Teresso SHP 220
Mobil	SHC 630
Q8/Kuwait Petroleum	Schumann 220
Shell	Paolina 220 Omala RL 220

The lists of recommended oil brands are not complete. Other oil brands may be used as long as they have equivalently quality as the brands recommended. The oil must have the same viscosity class and ought to follow the ISO standard 12925-1, category ISO-L-CKE (ISO 6743-6) or DIN 51517, part 3 CLP, but shall have a synthetic base oil of polyalphaolefin type (PAO) instead of mineral base oil. The oil must be endorsed for worm gear with brass worm wheel. The use of other lubricants than recommended is done on the exclusive responsibility of the user or oil supplier.

5.8.2 Gravity disc nomogram

Alfa Laval ref. 565798 rev. 0

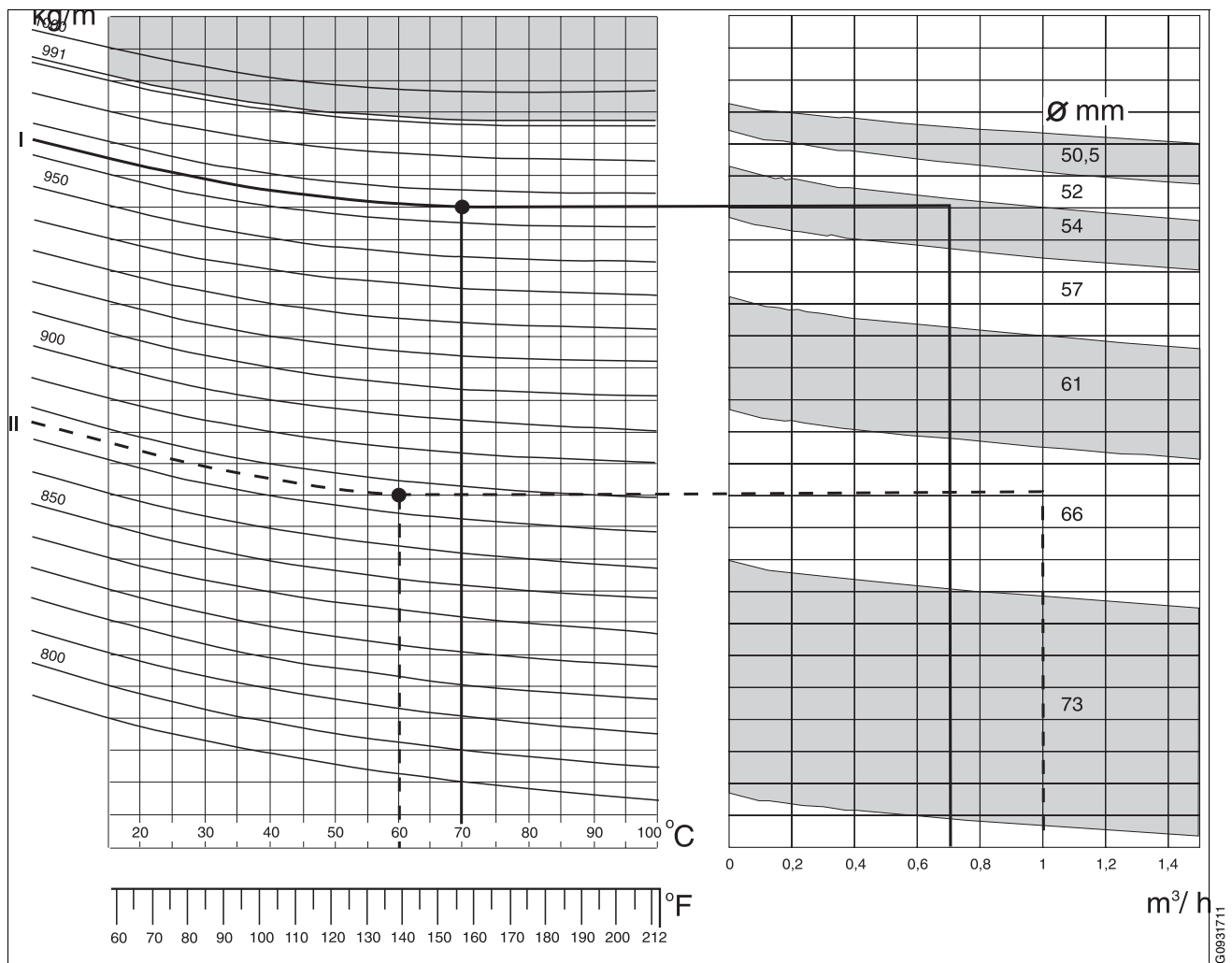

Oil density, kg/m³ at 15 °C
Oil temperature, °C, °F

Gravity disc hole diameter, Ø mm
Throughput, m³/h

The nomogram is based on the properties of fresh water.

Example I in nomogram		Example II in nomogram	
Reference in graph:	————	Reference in graph:
Oil density	965 kg/m ³ at 15 °C (60 °F)	Oil density	875 kg/m ³ at 15 °C (60 °F)
Separation temperature	70 °C (158 °F)	Separation temperature	60 °C (140 °F)
Throughput	0,7 m ³ /h	Throughput	1 m ³ /h
From the graphs (heavy line), the correct gravity disc has a hole diameter of 54 mm.		From the graphs (broken line), the correct gravity disc has a hole diameter of 66 mm.	

5.8.3 Electric motor

Alfa Laval ref. 552807, rev. 4

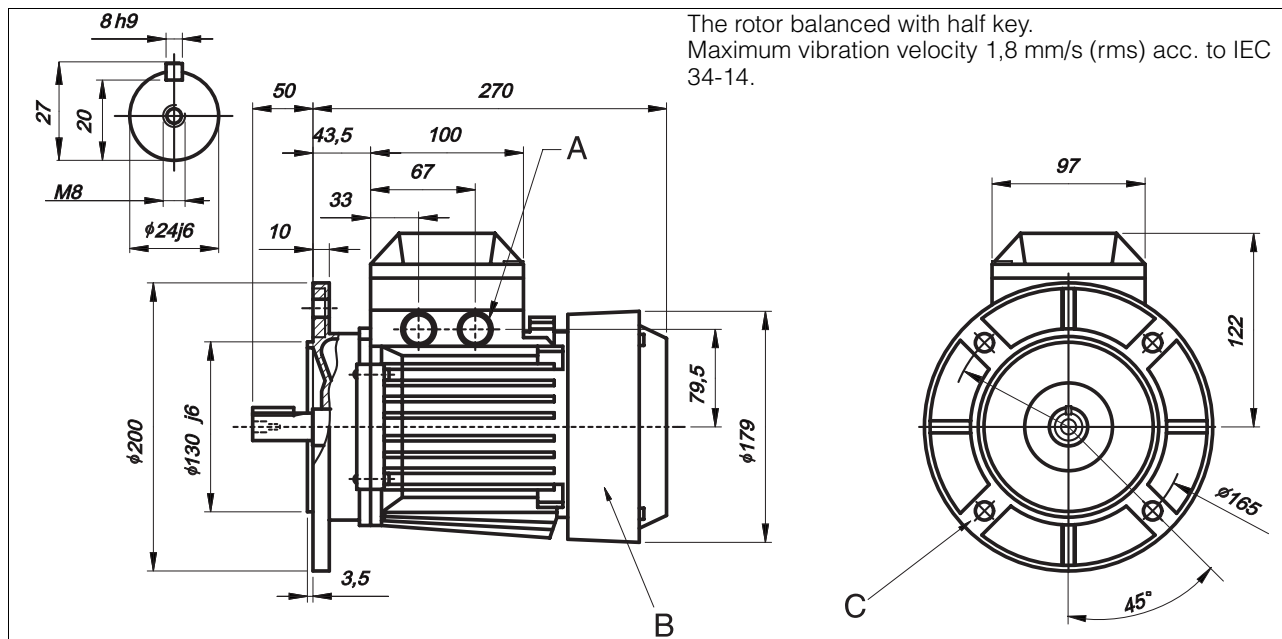





- A** Knock out openings for cable glands on both sides 2 x ø23
- B** Sheet-steel fan hood
- C** 4 holes ø12

NOTE

The motor bearings are permanent lubricated.

Manufacturer	ABB Motors
Manufacturers drawing	CAT. BA/Marine motors GB 98-05
Standards	IEC 34-series, 72, 79 and 85
Size	90L
Type	M2AA 90L
Weight	16 kg
Poles	2
Insulation class	F
Bearings	D-end 6305-2Z/C3, N-end 6204-2Z/C3
Method of cooling	IC 411 (IEC 34-6)
Specification	Totally enclosed three-phase motor for marine service ³⁾

Type of mounting IEC 34-7		Degree of protection IEC 34-5
	IM 1001	IP 55
	IM 3001	
	IM 3011	
	IM 3031	

Article No.	Output kW	Speed RPM	Freq. Hz	Voltage V	Current A	Power factor Cos. ϕ	$I_{st} / I^{(1)}$	Termist. °C ⁽²⁾	Note
552807-01	2,2	2870	50	220D 380Y	8,1 4,7	0,87	6,6		
552807-01	2,5	3460	60	220D 255D 440Y	8,0 8,1 4,7	0,90 0,87	5,9 6,8		
552807-01	2,2	3435	60	220D 255D 440Y	8,0 8,1 4,7	0,90 0,87	5,9 6,8		
552807-02	2,2	2870	50	415Y	4,3	0,87	6,6		
552807-03	2,2	2870	50	440 Y	4,1	0,87	6,6		
552807-04	2,2	2870	50	200Y	8,9	0,87	6,6		
552807-05	2,5	3460	60	240Y 220Y	4,7 9,4	0,87	6,8		Y-ser. Y-par.
552807-06	2,5	3460	60	460Y 230Y	4,5 9,0	0,87	6,8		Y-ser. Y-par.
552807-07	2,5	3460	60	575Y	3,6	0,87	6,8		CSA-plated
552807-09	2,2	2870	50	400Y	4,5	0,87	6,6		
552807-10	2,2	2870	50	230D	7,8	0,87	6,6		
552807-11	2,2	2870	50	500Y	3,6	0,87	6,6		
552807-12	2,2	2870	50	660Y	2,7	0,87	6,6		
552807-13	2,2	2870	50	690Y	2,6	0,87	6,6		
552807-14	2,5	3460	60	440Y	4,7	0,87	6,8		
552807-15	2,5	3460	60	460Y	4,5	0,87	6,8		
552807-16	2,5	3460	60	480Y	4,3	0,87	6,8		
552807-17	2,5	3460	60	690Y	3,0	0,87	6,8		
552807-18	2,5	3460	60	230D	9,0	0,87	6,8		
552807-19	2,5	3460	60	220D	9,4	0,87	6,8		
552807-20	2,5	3460	60	200D	10,3	0,87	6,8		
552807-21	2,5	3460	60	380Y	5,4	0,87	6,8		

1)	I _{st} / I = starting current / rated current at direction on line starting.	
2)	Thermistors tripping temperature if applicable.	
3)	The motors can be designed to fulfil requirements of following Classification Societies (Essential Service, if required).	
	Lloyds Register of Shipping (LRS)	Nippon Kaiyi Kyokai (NK)
	Det Norske Veritas (DnV)	Korean Register of Shipping (KR)
	Germanischer Lloyd (GL)	Polski Rejester Statkow (PRS)
	Bureau Veritas (BV)	China Classification Societies (CCS)
	American Bureau of Shipping (ABS)	Indian Register of Shipping (IRS)
	Registro Italiano Navale (RINA)	Maritime Register of shipping (RMS)

Required classification society must always be specified when ordering.

Factory test certificate to be enclosed at the delivery.

Rated output (kW) valid for temp-rise max. 90 °C.

The motors can be provided with space heaters for 110 V or 220 V, 25 W as option.

State supply voltage when ordering.

Connection to separate terminal board in the main terminal box acc. to attached connection diagram.

5.8.4 Machine plates and safety labels

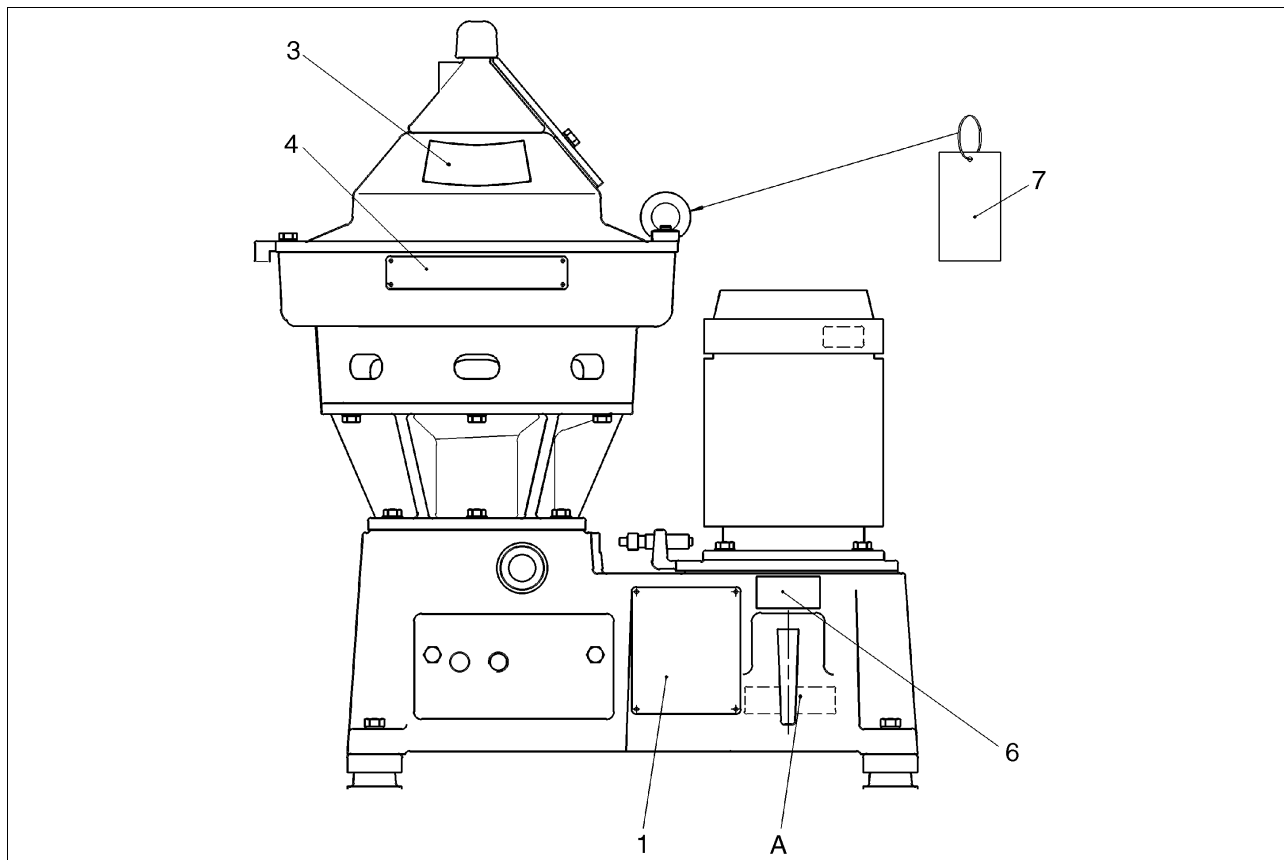

Location of machine plates and safety lables

1. Machine plate

Separator	P 605
Manufacturing serial No / Year	XXXX
Product No	881099-06-02/0
Inlet and outlet	561312-01
Bowl	561123-01
Machine bottom part	565390-01
Max. speed (bowl)	9512 r/min (50 Hz), 9307 r/min (60 Hz)
Direction of rotation (bowl)	←
Speed motor shaft	3000 r/min (50 Hz), 3600 r/min (60 Hz)
El. current frequency	50/60 Hz
Recommended motor power	2,2 kW (50 Hz), 2,2 kW (60 Hz)
Max. density of feed	1100 kg/m ³
Max. density of sediment	2631 kg/m ³
Process temperature min./max.	0/+100 °C

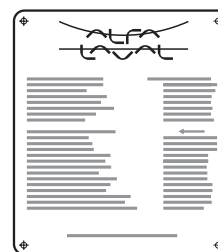

3. Safety label

Text on label:

WARNING

Read the instruction manuals **before** installation, operation and maintenance.
Consider inspection intervals.

Failure to strictly follow instructions can lead to fatal injury.

If excessive vibration occurs, **stop** separator and **keep bowl filled** with liquid during rundown.

Out of balance vibration will become worse if bowl is not full.

Separator must **stop rotating** before **any** dismantling work is started.

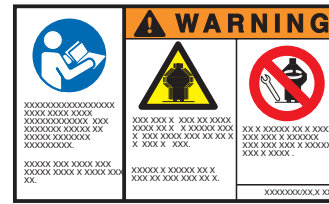

S00690N1

4. Name plate

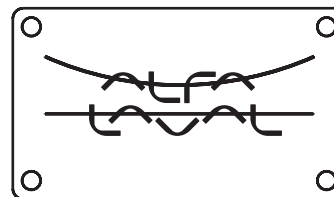

S0063211

6. Power supply frequency

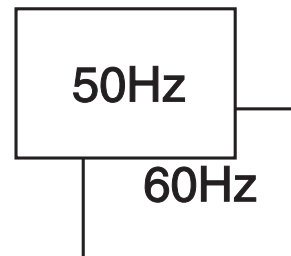

S0063111

7. Label

Text on label:

Read the instruction manual before lifting.

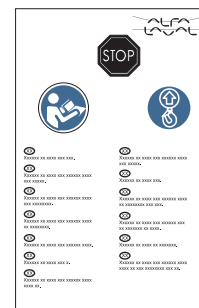

S0069111

A. Space for label indicating representative

5.8.5 Operating water interface (Purifier)

Alfa Laval ref. 565819, rev. 0

Proposed operation of operating water interface for purifier execution.

Closing the bowl and supplying liquid seal:

- 1** Initialise by opening connection 372 for 1 second.
- 2** Close the bowl by opening connection 373 for 40 seconds.
- 3** Supply liquid seal by opening connection 206 for 12 seconds.
- 4** Open the feed (connection 201).

Starting sequence illustrated graphically:

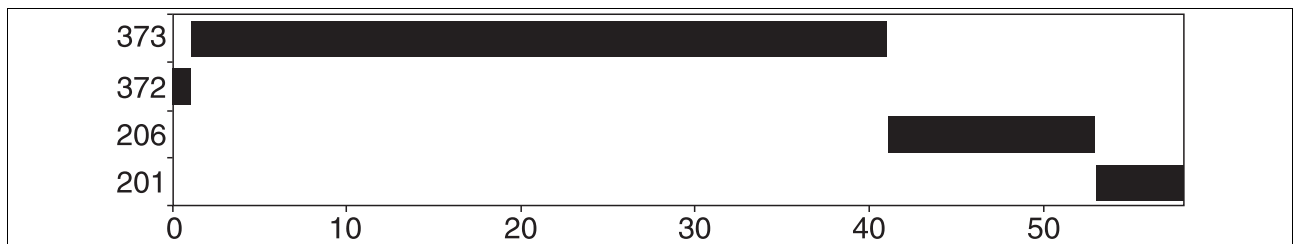

Performing a discharge:

- 1** Close the feed (connection 201).
- 2** Open connection 373 and perform a displacement (of the interface) by opening connection 206.
- 3** After 8 seconds open connection 372 during 1 second.
- 4** After another 12 seconds close connections 206 and 373.
- 5** Open the feed (connection 201).

Discharge sequence illustrated graphically:



During the separating process the make-up water supply volume is maintained by opening connection 373 for 2 seconds every 15 minutes.

5.8.6 Operating water interface (Clarifier)

Alfa Laval ref. 565849, rev. 0

Proposed operation of operating water interface
for clarifier execution.

Closing the bowl:

- 1** Initialise by opening connection 372 for 1 second.
- 2** Close the bowl by opening connection 373 for 40 seconds.
- 3** Open the feed (connection 201).

Starting sequence illustrated graphically:

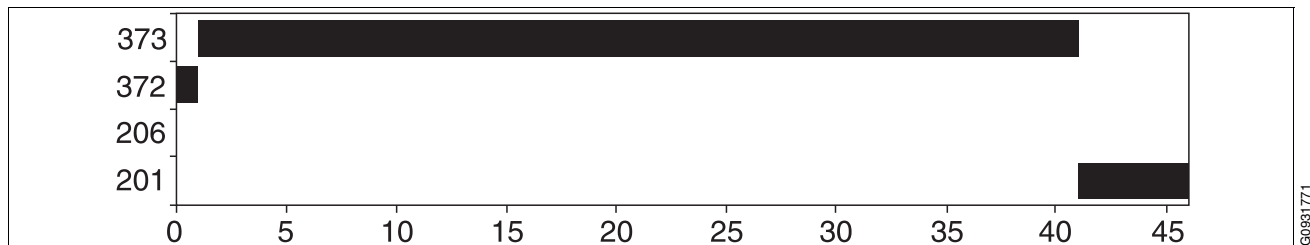

Performing a discharge:

- 1** Close the feed (connection 201).
- 2** Open connection 373.
- 3** After 12 seconds open connection 372 during 1 second.
- 4** After another 15 seconds close connection 373.
- 5** Open the feed (connection 201).

Discharge sequence illustrated graphically:

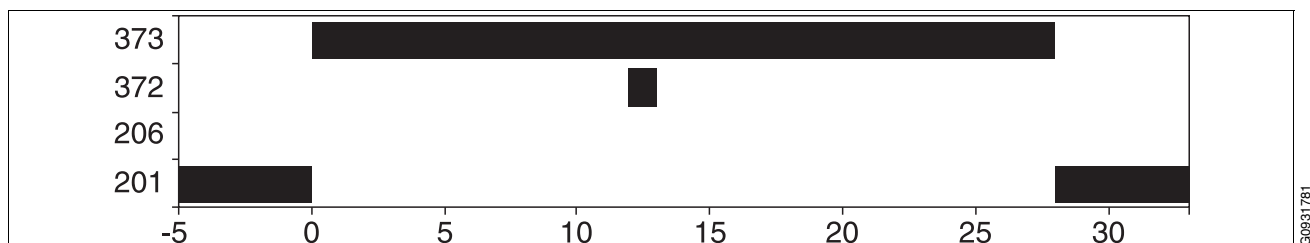

During the separating process the make-up water supply volume is maintained by opening connection 373 for 2 seconds every 15 minutes.

**5.8.7 Performance data,
in- and outlet device**

Alfa Laval ref. 565805, rev. 0

**Maximum light phase counter pressure as a
function of throughput and viscosity:**

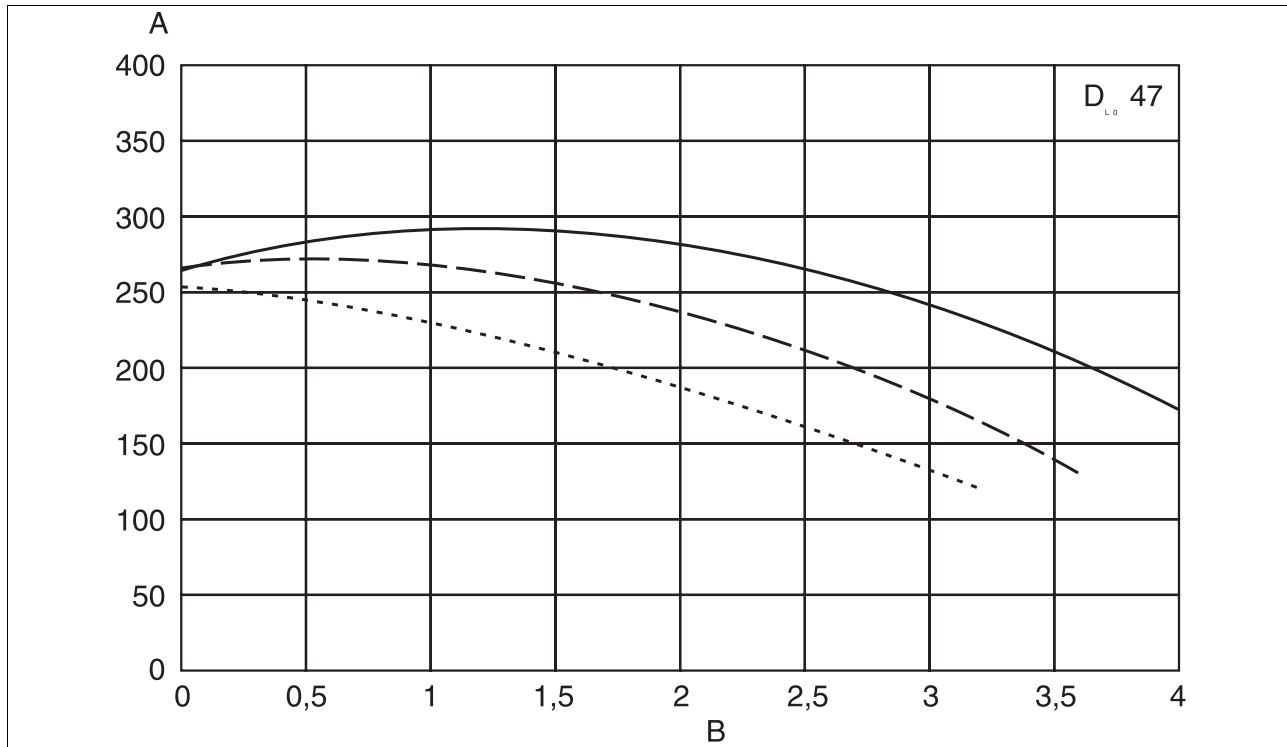

A. Max. light phase counter pressure, kPa
 B. Light phase throughput, m³/h

10 cSt —————
 30 cSt - - - - -
 48 cSt

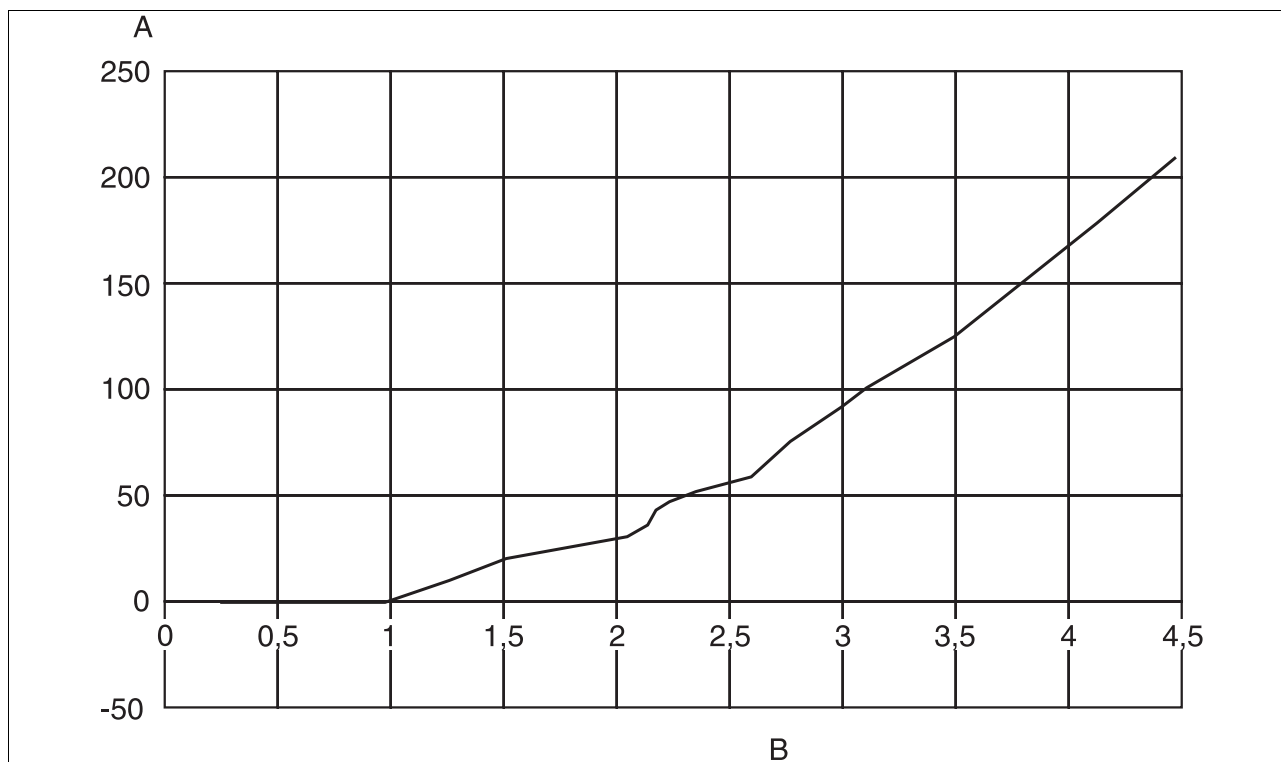
Inlet pressure as a function of throughput and viscosity

- A. Pressure kPa
B. Throughput m³/h

G0981731

Maximum heavy capacity as a function of gravity disc:

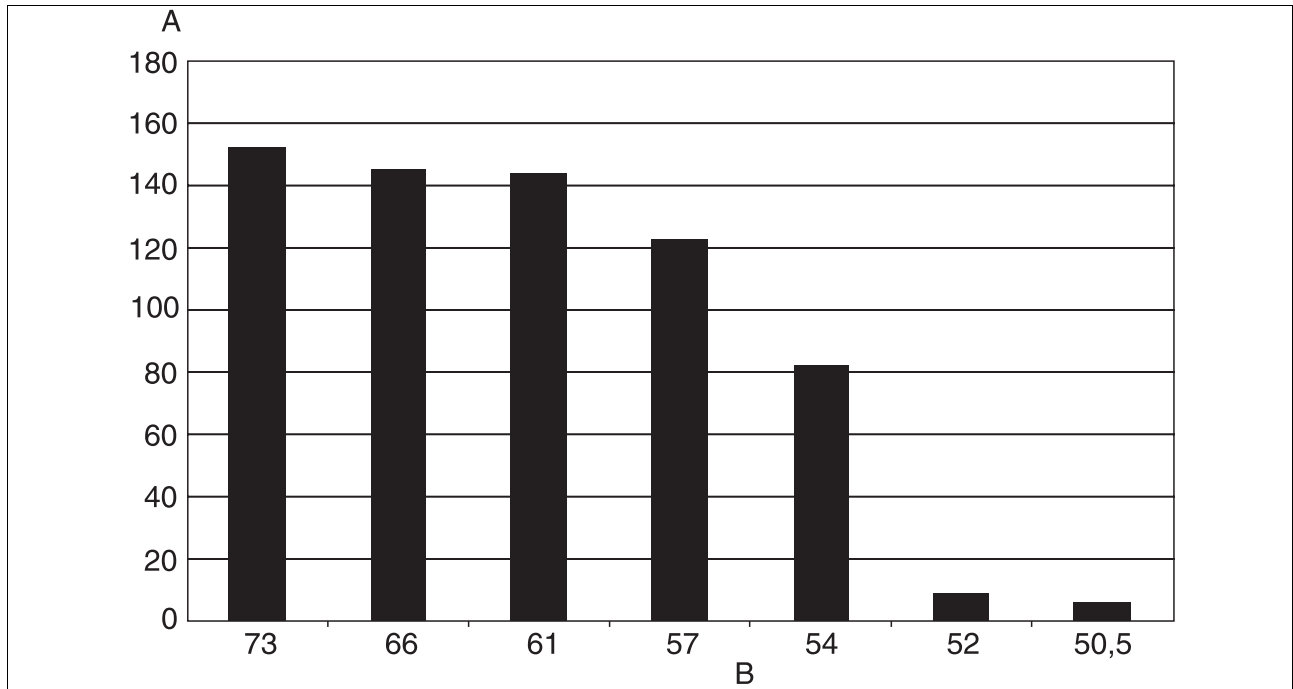

A. litres/hour
 B. Gravity disc

5.8.8 Interconnection diagram

Alfa Laval ref. 561723, rev. 0

1	
2	Reset Coil
3	NO
4	Common
5	NC
6	
7	Heater
8	

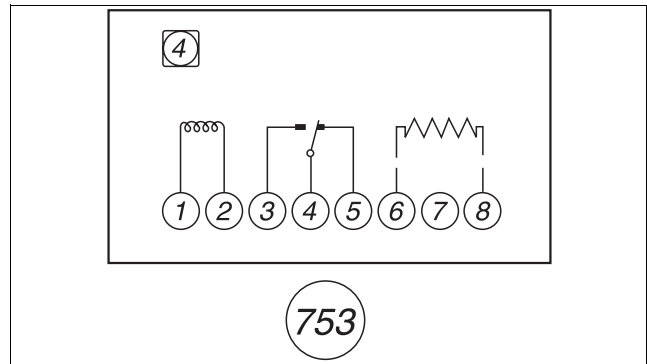

Vibration sensor (mechanical switch)

5.9 Storage and installation

5.9.1 Introduction

These installation specifications are valid for the S 300 separator.

The installation instructions are specifications, which are compulsory requirements.

Any specific requirements from classification societies or other local authorities must be followed.

NOTE

If the specifications are not followed, Alfa Laval can not be held responsible for any malfunctions related to the installation.

5.10 Protection and storage of goods

- a** The separator must be stored indoors at 5 - 55 °C, if not delivered in a water-resistant box, designated for outdoor storage.

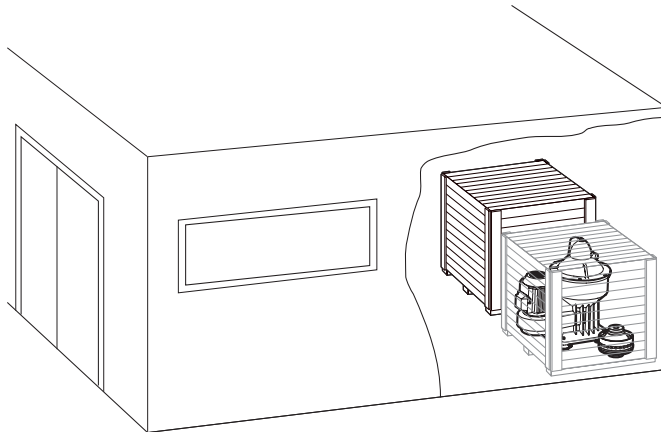

The following protection products are recommended:

- 1** Anti-rust oil (Dinitrol 112 or equivalent) with long lasting effective treatment for external surfaces. The oil should prevent corrosion attacks and leaves a waxy surface.
- 2** Anti-rust oil (Dinitrol 40 or equivalent) is a thin lubricant for inside protection. It gives a lubricating transparent oil film.
- 3** Solvent, e.g. white spirit, to remove the anti-rust oil after the storage period.
- 4** Moist remover to be packed together with the separator equipment.

- b** If there is a risk for water condensation, the equipment must stand well ventilated and at a temperature above dew point.

- c** If the storage time exceeds 12 months, the equipment must be inspected every 6 months and, if necessary, the protection be renewed.

5.10.1 Storage at out of operation

If the separator is out of operation for more than 1 month:

- 1** Lift out the bowl.
- 2** Protect the spindle taper from corrosion by lubricating it with oil.
- 3** Keep the separator and bowl well stored, dry and protected from mechanical damage.

For details see [5.10 Protection and storage of goods, page 152](#)

5.10.2 Before start-up

If the separator has been out of operation for:

1 months or longer

- Pre-lubricate the spindle bearings.

6 months or longer

- Perform an Inspection service  and make sure to pre-lubricate the spindle bearings.
- Change the oil before starting.

18 months or longer

- Perform an Overhaul service  and make sure to pre-lubricate the spindle bearings.
- Change the oil before starting.

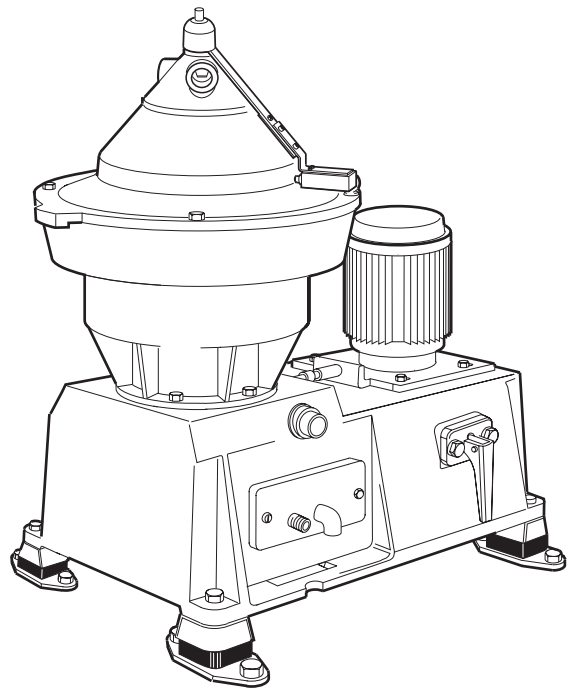

G0464881

5.10.3 Connections to surrounding equipment

Local safety regulations

If the local safety regulations prescribe that the installation has to be inspected and approved by responsible authorities before the plant is put into service, consult with such authorities before installing the equipment and have the projected plant design approved by them.



G0873911

Service media

Ensure that all service media (electric power, operating and safety liquids etc.) required for the separator have the correct quality and capacity.

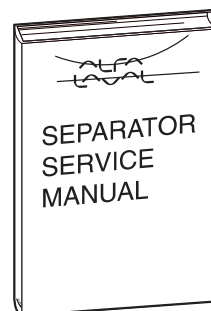

G0874021

Sludge discharge tank

If the sediment from the separator is discharged into a tank, this tank must be sufficiently ventilated. The connection between the separator and the tank must be of the size and configuration specified.

If the solids are discharged from the separator bowl casing into a closed system, ensure that this system cannot be overfilled or closed in such a way that the solids cannot leave the bowl casing. This could cause a hazardous situation.

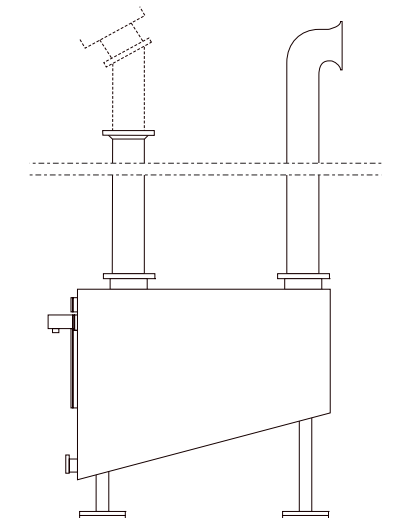

G0874311

Valves, Pipes and Similar Equipment

- Components like valves need to be cleaned with solvent and treated with anti-rust oil (type 112).
- Water pipes should be drained and treated with anti-rust oil (type 112).
- Articles made of rubber or plastics (e.g. seals) must *not* be treated with anti-rust oil.

5.10.4 Reassembly and Start up

- Clean away the anti-rust oil with white spirit.
- Remove the silica gel bags from all units.
- Follow all relevant instructions in the *Service Manual* and *Operating Instructions*.

5.10.5 Storage and transport of goods**Storage****Specification**

Upon arrival to the store, **check all components and keep them:**

- 1** Well stored and protected from mechanical damage.
- 2** Dry and protected from rain and humidity.
- 3** Organized in the store in such a way that the goods will be easily accessible when installation is about to take place.

A separator can be delivered with different types of protection:

- Fixed on a pallet.

The separator must be stored in a dry storage room, protected from rain and humidity. It must be well protected from mechanical damage.

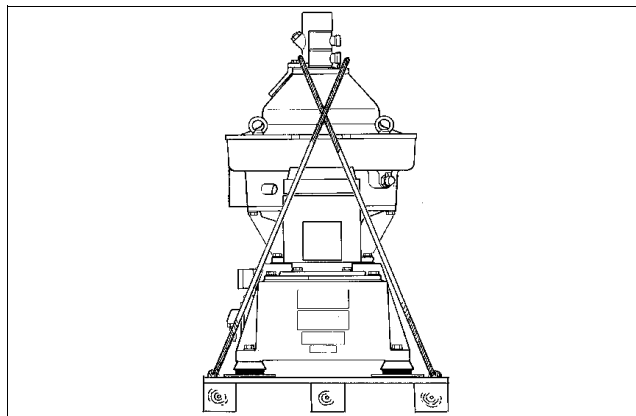

Fixed on a pallet

- In a wooden box which is not water tight.

The separator must be stored in a dry storage room, protected from rain and humidity.

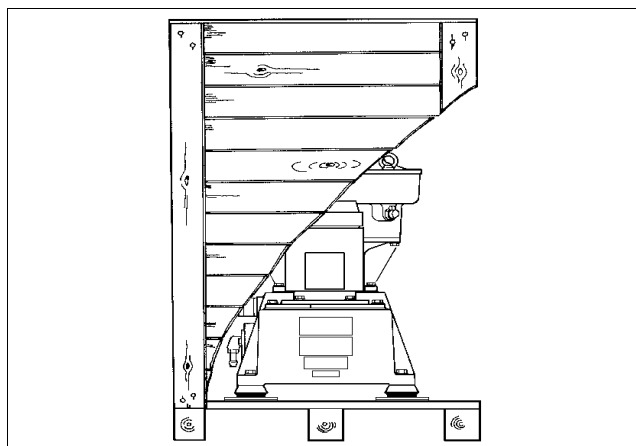

In a wooden box which is not water tight

- In a special water-resistant box for outdoor storage.

The separator and its parts have been treated with an anti-corrosion agent. Once the box has been opened, store dry and protected from rain and humidity.

The packaging for outdoor storage is only to special order.

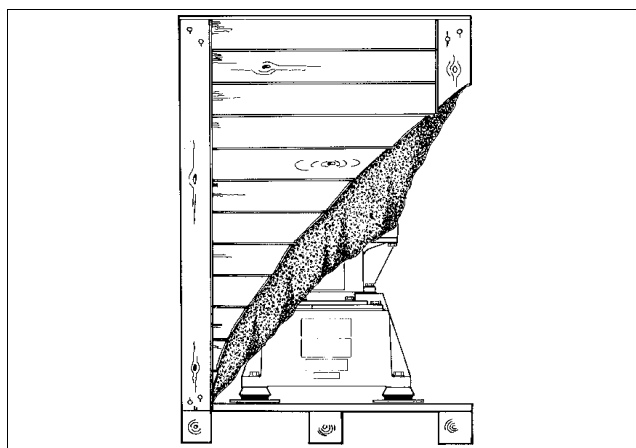

In a special water-resistant box for outdoor storage

Transport

Specification

- During transport of the separator, the bowl must always be removed from the machine and transported separately.
- When lifting a separator it must always be hung securely. See details in chapter 3.6 [Lifting instructions, page 52](#).



Crush hazard

Use correct lifting tools and follow lifting instructions.

- During erection, all inlets and outlets to separators and accessories must be covered to be protected from dust and dirt.

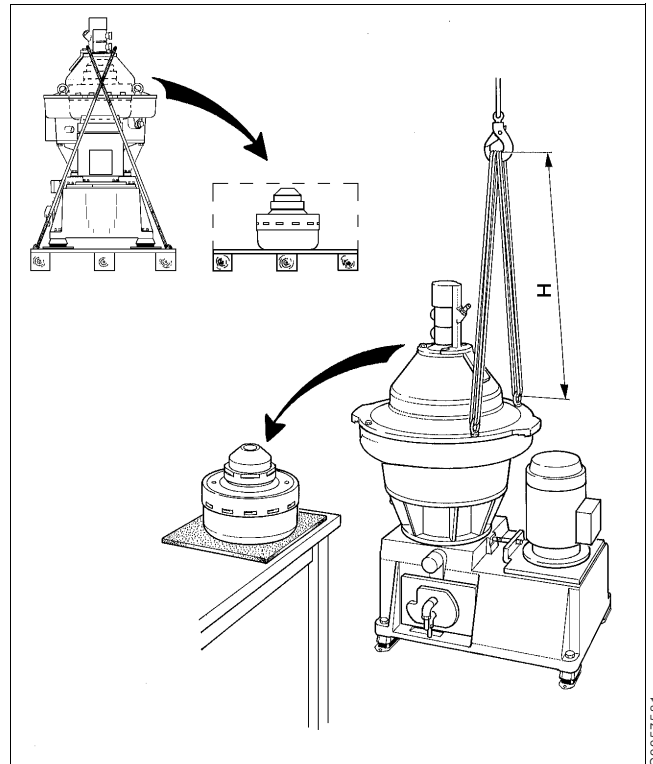

$H = \text{minimum } 750 \text{ mm}$

G0057581

5.10.6 Planning of installation

Introduction

The space required for one or more separators can be calculated by consulting [5.4 Basic size drawing, page 122](#), and instructions for ancillary equipment, electrical and electronic equipment and cables.

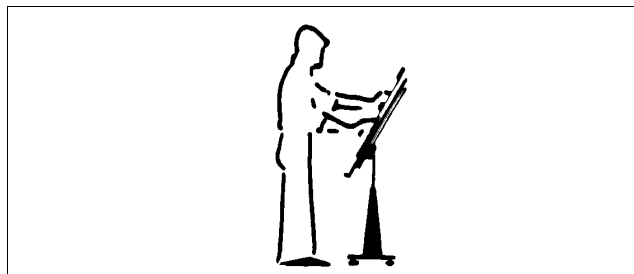

Check the drawings when planning the installation

Important measurements

Important measurements are the minimum lifting height for lifting tackle, shortest distance between driving motor and wall, free passage for dismantling and assembly, maintenance and operation.

Plan your installation with sufficient room for the controls and operation so that instruments are easily visible. Valves and controls must be within convenient reach. Pay attention to space requirements for maintenance work, work benches, dismantled machine parts or for a service trolley.

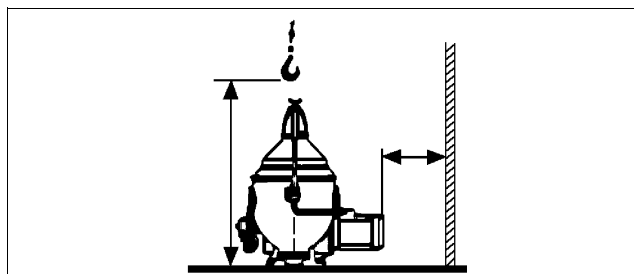

Suitable space must be obtained for the maintenance work

Space for separator

The separator shall be placed in such a way that suitable space for maintenance and repair is obtained.

Specification

See the [5.8.1 Foundation plan, page 140](#) for the service space required with the separator installed.

Recommendation

The spanner for the bowl hood should have sufficient space to make a complete turn without touching any of the ancillary equipment surrounding the separator.

Lifting height for transport of bowl**Specification**

A minimum height is required to lift the bowl, bowl parts and the bowl spindle, see the drawing [5.8.1 Foundation plan, page 140](#).

Recommendation

When two or more separators are installed, the lifting height may have to be increased to enable parts from one separator to be lifted and moved over an adjoining assembled separator.

Space for oil changing**Specification**

The oil filling device must not be blocked by floor plate arrangement, etc.

Recommendation

It should be possible to place a portable collecting tray under the oil filling device drain hole.

5.10.7 Foundations

NOTE

When lifting a separator it must always be hung securely. see separate lifting instructions in this book.

- See [5.8.1 Foundation plan, page 140](#).
- The separator must be installed on a strong and rigid foundation to reduce the influence of vibrations from adjacent machinery.
- The foundation should be provided with a cofferdam.
- Fit the separator frame on the foundation as follows:
 - Check that the bolts do not press against the edges of the holes, otherwise the elasticity of the mounting of the separator frame will be impeded.
 - Fit height adjusting washers required.
 - Check that the separator frame is horizontal and that all feet rest on the foundation.
 - Tighten the screws.

6 Operating

Contents

6.1 Operating routine	162
6.2 Before first Start	162
6.2.1 Selection of gravity disc	163
6.3 Start after a service	164
6.3.1 Before normal start	164
6.3.2 Starting and running-up procedure	167
6.3.3 Separation	168
6.3.4 Stopping procedure	169
6.3.5 Safety stop	170
6.4 After Safety Stop	171

6.1 Operating routine

These operating instructions describe routine procedures to follow before and during the start, running and stopping sequences of the separator.

If system documentation is available always follow the operating instructions of this. If there is no system documentation the instructions below are to be followed.

6.2 Before first Start

Technical demands for connections and logical limitations for separator are listed in chapter **“Technical Reference”** on page 117.

- 1 Ensure that the separator is correctly installed and that feed lines and drains have been flushed clean.



Breakdown hazard

Assemble the separator completely before start. All couplings, covers, and guards must be in place and properly tightened. Non compliance may lead to breakdown.



Electrical hazard

Follow local regulations for electrical installation and earthing (grounding).



Breakdown hazard

Check that the power frequency is in agreement with the machine plate. If incorrect, resulting overspeed may cause breakdown.



Use the separation system for the purpose, and within the limits, specified by Alfa Laval. Failure to do so could cause a violent breakdown.

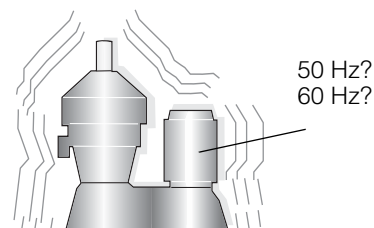
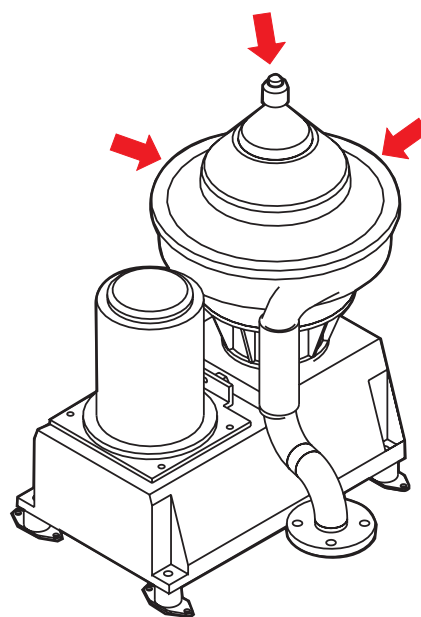

2 Check the oil sump level. Top up if necessary.

- The oil level should be slightly above middle of the sight glass.

NOTE

Too much or too little oil can damage the separator bearings.

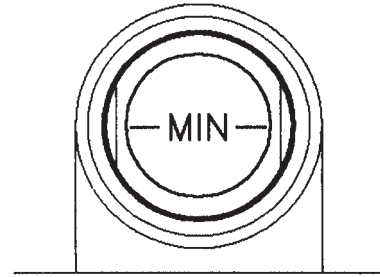

G0866543

6.2.1 Selection of gravity disc

The separator is delivered with a set of gravity discs with different diameters for purification operation. The hole diameter of the gravity disc sets the position of the oil/water interface in the separator, see page 21. The separation efficiency can be optimized by selection of the correct diameter for each oil quality.

As a guide the [5.8.2 Gravity disc nomogram, page 141](#) can be used. The size of the first gravity disc to be tried can be read directly from the nomogram.

The best separation results are obtained by using a gravity disc with as large size as possible, which will not cause a broken water seal in the bowl or an emulsification in the water outlet.

The presence of salt water in the oil may demand the use of a gravity disc with bigger hole than indicated in the nomogram. The nomogram is based on the properties of fresh water in the oil.

For operating the separator as a clarifier the diameter of the disc should be 40 mm.

6.3 Start after a service

Pay special attention to unusual conditions when starting the separator after a service.

6.3.1 Before normal start

Check these points before every start.

1. Make sure that the bowl is clean and that the separator is properly assembled.
2. Make sure that the bolts of the outlet cover and the frame hood are fully tightened.

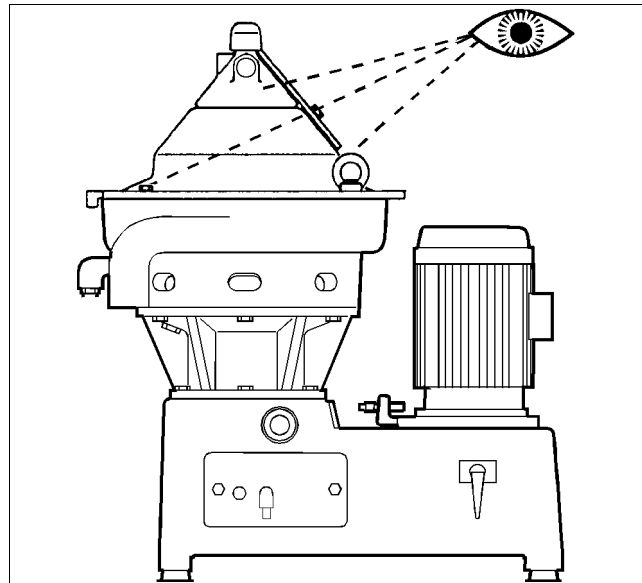

Check assembly and tightenings

3. Make sure that all couplings and connections are securely tightened to prevent leakage.



Slip hazard
Check all connections for leakage.
Oil leakage may make the floor slippery.

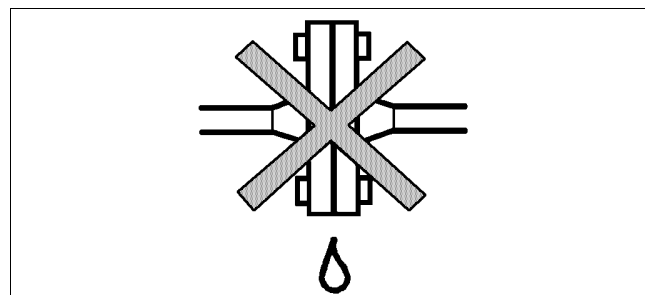

Check for leakages (not admitted)

4. Make sure that the inlet pipe is tightened.

5. Read the oil level. The line in the middle of the sight glass shows the **minimum** level. Refill if necessary.

For grade and quality of oil see [5.7 Lubricants](#), page 133.

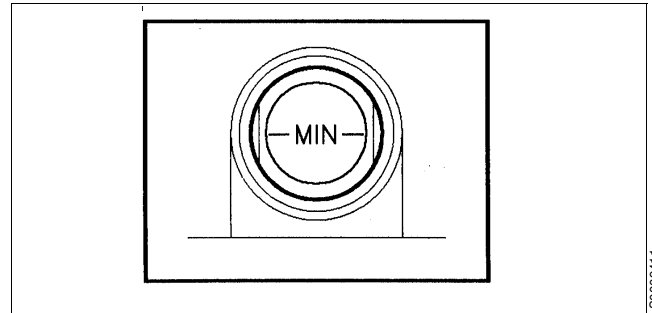

Check the oil level

Rotation Direction

Check the rotation of the bowl by doing a quick start/stop. The motor fan must rotate in a clockwise direction.



If power cable polarity has been reversed, the separator will rotate in reverse, and vital rotating parts can loosen.

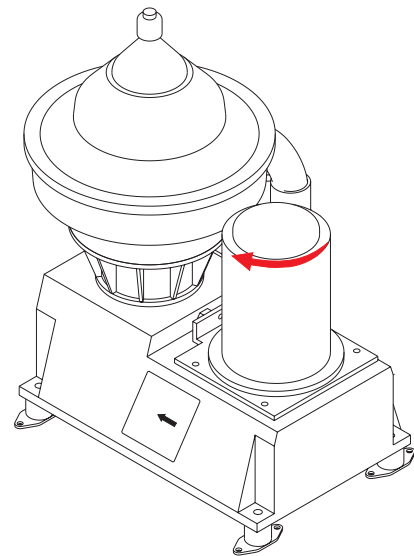

Disintegration hazards

After change of feed the sludge discharge interval must be adjusted. Too long intervals between discharges can result in breakdown.



Burn hazard

Avoid contact with hot surfaces. Process pipes, various machine surfaces, and processed liquid can be hot and cause burns.

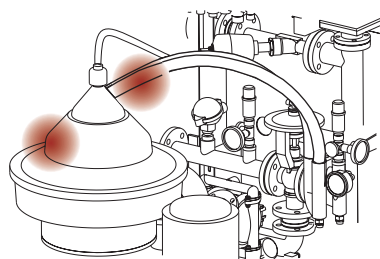

P004073C

6.3.2 Starting and running-up procedure

1. Open the water supply valve(s). Make sure that the water supply is on 150-600 kPa (1,5-6 bar).
2. Start the separator.
3. Be alert for unusual noises and conditions.
4. Note the normal occurrence of critical speed periods. Some vibrations occur for short periods during the starting cycle, when the separator passes through its critical speeds. This is normal and passes over without danger. Try to learn the vibration characteristics of the critical speed pattern.

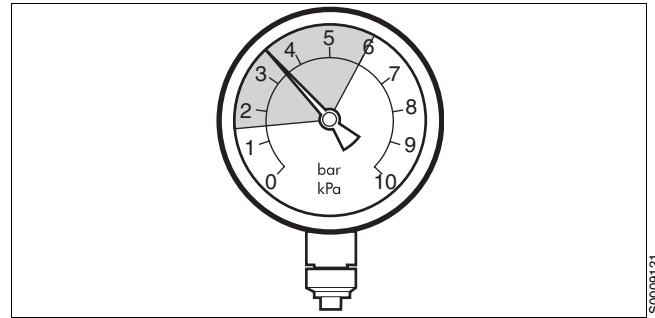

Water supply



Disintegration hazards

When excessive vibration occurs, keep bowl filled and stop separator.

The cause of the vibration must be identified and rectified before the separator is restarted.

Excessive vibration may be due to incorrect assembly or insufficient cleaning of the bowl.

5. Check the current to the separator motor to ensure that the separator has reached full speed:

During start, the current reaches a peak and then slowly drops to a low and stable value.

For normal length of the start-up period see [5.2 Technical data, page 119](#).

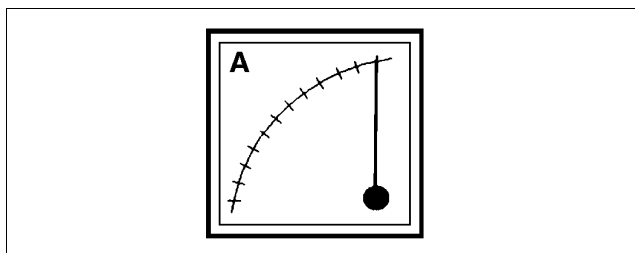

Current increases during start...

6. For **purification**:

- a. Supply water to form the water-seal. The water should have the same temperature as the process liquid.
- b. Close the water feed when water flows out through the water outlet.
- c. Start the oil feed slowly to avoid breaking the water seal.

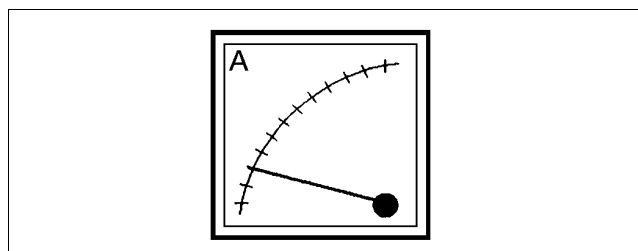

... to decrease to a stable value when full speed has been reached

7. For **clarification**:

- a. Start the oil feed with full flow.

8. For both **purification** and **clarification** modes:

Check the separator inlet and outlet pressures. See recommended values in your system documentation.

9. Adjust to desired throughput.

6.3.3 Separation

Do regular checks on:

- oil inlet temperature (if applicable)
- water collecting tank level (if applicable)
- sound/vibration of the separator
- back pressure
- motor current.

6.3.4 Stopping procedure

1. Turn off the oil feed.
2. Feed displacement water until water flows out through the water outlet. Then close this feed.
3. Stop the separator.
4. Wait until the separator has come to a complete standstill.

Remove the safety device and look through the slot in the frame hood to see the movement of the bowl.

Separator standstill

Dismantling work must not be started before all rotating parts have come to a complete standstill.



Entrapment hazard

Make sure that rotating parts have come to a complete standstill before starting any dismantling work.

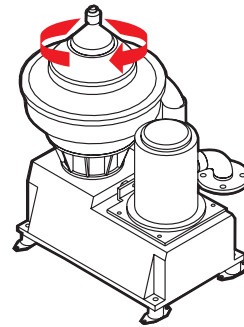

6.3.5 Safety stop

If the separator begins to **vibrate** excessively during operation, stop it immediately by pushing the **safety stop**. The separator motor is switched off.

- Keep the **bowl filled** during the run-down to minimize the excessive vibration.

Evacuate the room. The separator may be hazardous when passing its critical speeds during the run-down.

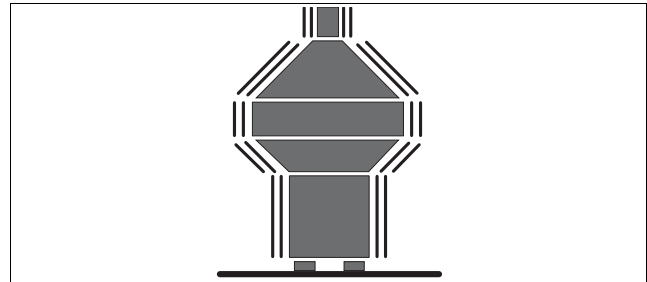

S0055611

Hazard!

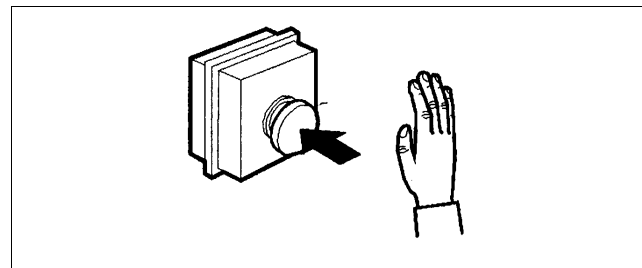
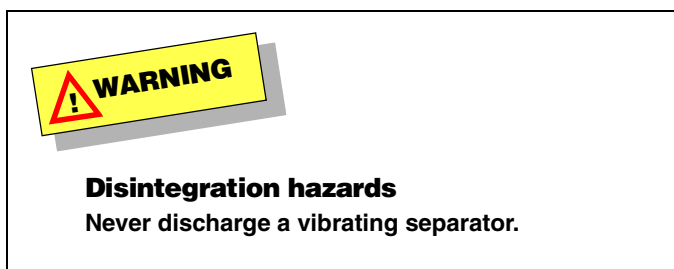

S0009911

Push the safety stop!

6.4 After Safety Stop

Separator standstill

Dismantling work must not be started before all rotating parts have come to a complete standstill.



Entrapment hazard

Make sure that rotating parts have come to a complete standstill before starting any dismantling work.

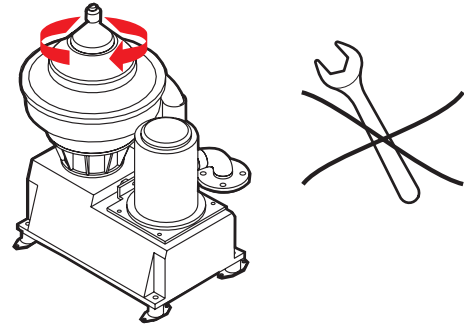

100293CB

Avoid accidental start



Entrapment hazard

To avoid accidental start, switch off and lock power supply before starting any dismantling work.

Make sure that separator has come to a complete standstill before starting any dismantling work

Remedy the cause

The cause of the emergency must be remedied before attempting to restart the separator.

If the cause is not found, an overhaul must be performed on the separator, and all moving parts thoroughly checked



Disintegration hazard

Do not start the separator after an emergency stop without first remedying the cause of the emergency.

Make sure that the bowl is clean before restart.

Separator reassembled

The separator must be fully reassembled with all covers and guards in place and tightened before unlocking the power supply and starting the system.

**Breakdown hazard**

Assemble the separator completely before restart. All couplings, covers, and guards must be in place and properly tightened. Non compliance may lead to breakdown.

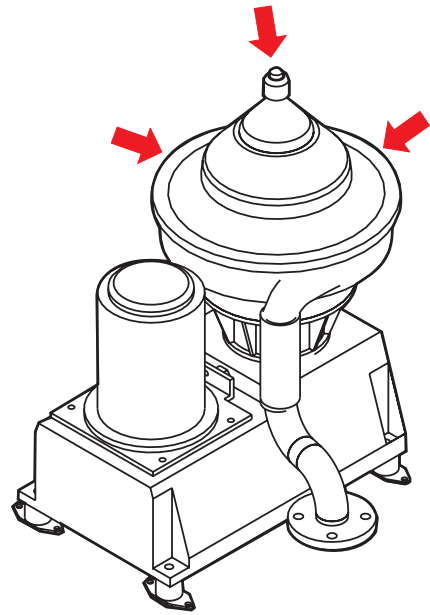

P003595B