

7.1.12.3-1 Foundation Drawing, P 600/P 610

7. Components - 1 Separators - 12 P Separator  
MIDPC Acrobat Enclosure

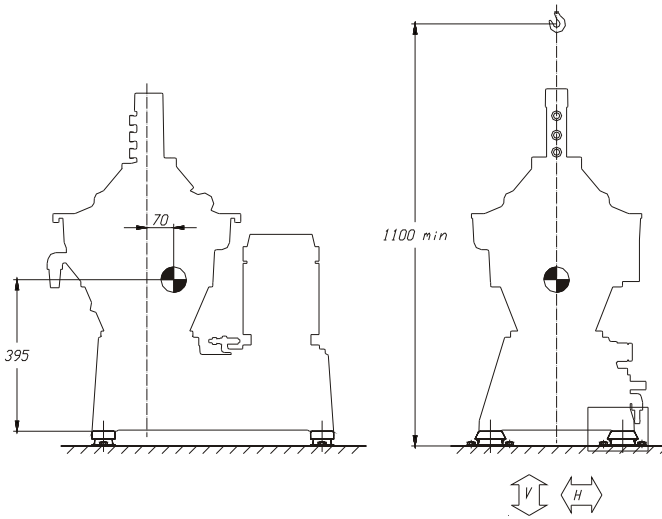

- Recommended free floor space for unloading when doing service
- No fixed installation within this area
- ⊗ Center of gravity (Complete machine)
- ⬆ Vertical force not exceeding 5 kN/foot
- ⬅ Horizontal force not exceeding 7 kN/foot
- Total static load max. 4 kN

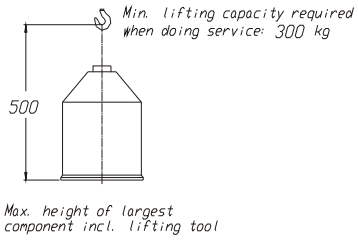
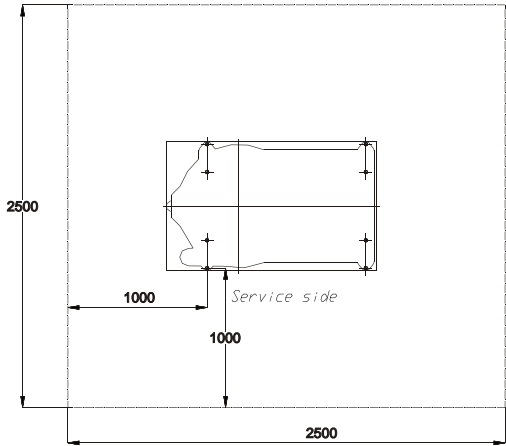