

7.Components - 5 Control and Monitoring Units - 19 Control Unit, PA

MIDPC Acrobat Enclosure

7.5.19.1 Dimension Drawing, Control Unit, PA

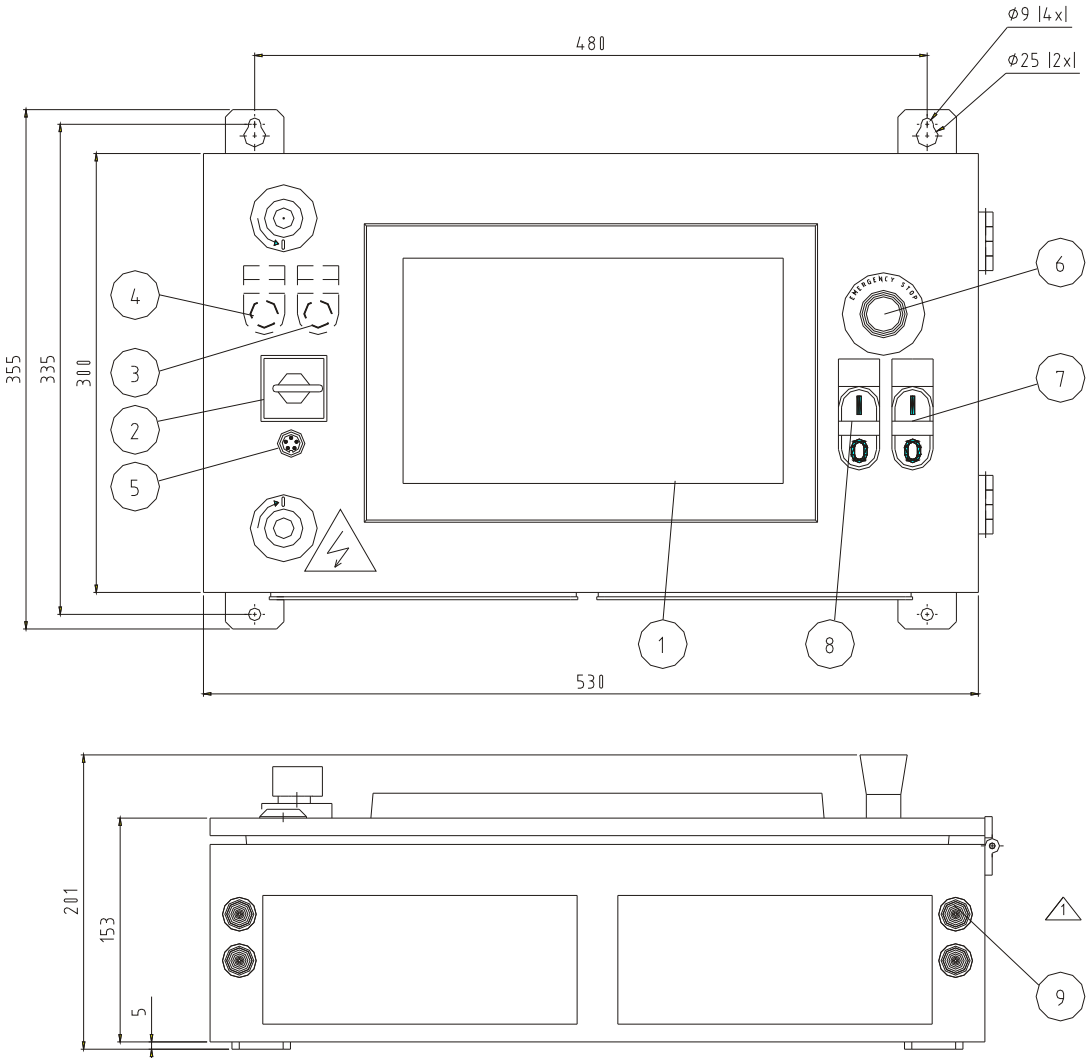

TECHNICAL DATA

AMBIENT TEMPERATURE: MAX 55°C
 PROTECTION CLASS: IP 65
 MATERIAL IN CABINET: SHEET OF STEEL
 POWER SUPPLY: 100,115 or 230 V AC 50/60 Hz
 OPERATING VOLTAGE: 24 V AC 50/60 Hz
 POWER CONSUMPTION: 70 VA
 WEIGHT: 19 kg

LEGEND

1. Operating Panel
2. Selector Switch CIP/MAN/AUT
3. Sludge Valve Interlock indication (optional)
4. Separator Interlock indication (optional)
5. PC connection
6. Emergency Stop, Separator
7. On-Off, Feed Pump
8. On-Off, Separator
9. Plugd holes for extra cable glands

--- Optional *

568304 04	EPC 50 P-Controller	(Flextr. 31830 6205 3)
568304 03	Sludge valve interlock *	(Flextr. 31830 6575 1)
568304 02	Separator interlock *	(Flextr. 31830 6574 1)
568304 01	EPC 50 S-controller	(Flextr. 31830 6205 2)

Ref. 568304 Rev. 3

Marine Product Catalogue

Illustrations, indications of material, dimensions and weights etc herein, do not constitute any commitment on our part. We reserve the right to change such specifications when necessary.