



MMB

Solids-Retaining Centrifugal Separators

Application

Purification or clarification (optional) of mineral oils used in marine installations and power stations:

- distillates
- Marine Diesel Oils MDO up to 13 cSt at 40°C
- lubricating oils for trunk diesel engines operating on distillates and light MDO
- lubricating oils for steam and gas turbines
- lubricating and hydraulic oils for hydroelectric power stations.

Concept

The MMB series of solids-retaining separators is available in two models, the MMB 304 and MMB 305.

Each MMB separation system comprises:

- an MMB separator
- ancillary equipment consisting of connections and valve assembly.

Optional equipment

- independent oil feed pump
- oil heating system, steam or electric
- water seal alarm MAWA-40.

Features and benefits

The unique features of the system are:

- compact, robust design
- internal paring disc for discharge of clean oil
- large sludge space
- belt-driven.

The major benefits are:

- Easy to install.
Requires limited space.
- Pressurised discharge of clean oil.
No need for downstream pump.
- Fewer service manhours.
Larger sludge space extends operating period between manual cleaning.
- Lower maintenance and spare parts costs.



Fig. 1 MMB 305 solids-retaining separator.



Fig. 2 Water seal alarm MAWA-40.

System working principle

Separation takes place in a solids-retaining, also known as a solid-wall, bowl that can be arranged for purification or clarification (optional). In both cases the contaminated oil is fed to the separator by a feed pump through the oil inlet and is separated by centrifugal force into its various phases. The heaviest phase, sludge, is forced to and deposited at the periphery of the bowl. Separated sludge is collected in the space at the periphery of the bowl and removed periodically by hand using the stainless steel sludge basket. The clean oil is continuously discharged by the built-in paring disc pump. Water leaves the bowl via an open outlet.

When operated in purifier mode, a gravity disc must be fitted to obtain the correct interface position (the boundary between the separated oil and the water seal) in the separator bowl. In the optional clarifier mode, a clarifier disc is fitted instead of a gravity disc.

A MAWA-40 water seal alarm is available as optional equipment to monitor the pressure in the clean oil outlet. The control unit will shut off the oil feed to the separator in case a pressure drop is detected and give an audible and visible alarm.

Installation

The MMB separation system is designed for installation as a complete system. The schematic layout in Fig 4. shows a typical installation of an MMB separator. Contaminated fuel or oil is supplied by the feed pump from the oil tank to the separator bowl for continuous cleaning.

After separation, the cleaned oil is discharged by a built-in paring disc pump.

The complete system includes MAWA water seal alarm, starter, heater, valves, piping and other essential ancillary equipment.

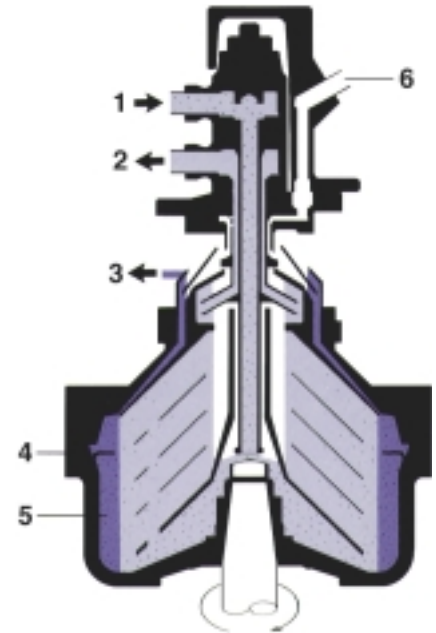
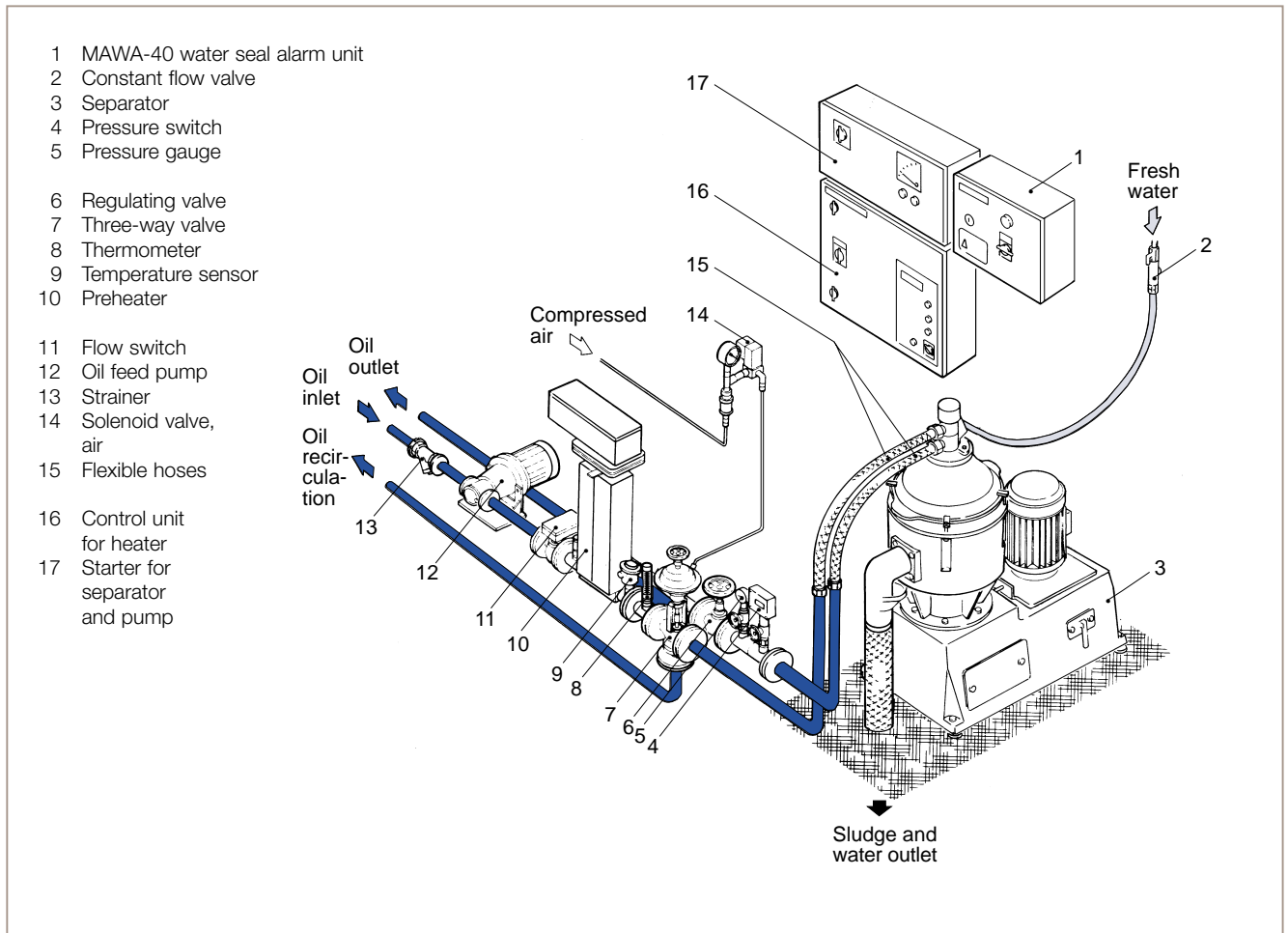

Fig. 3. Purifier-Clarifier.

- | | |
|-----------------|------------------------|
| 1. Oil inlet | 4. Sludge basket |
| 2. Oil outlet | 5. Sludge |
| 3. Water outlet | 6. Sealing water inlet |



- 1 MAWA-40 water seal alarm unit
- 2 Constant flow valve
- 3 Separator
- 4 Pressure switch
- 5 Pressure gauge
- 6 Regulating valve
- 7 Three-way valve
- 8 Thermometer
- 9 Temperature sensor
- 10 Preheater
- 11 Flow switch
- 12 Oil feed pump
- 13 Strainer
- 14 Solenoid valve, air
- 15 Flexible hoses
- 16 Control unit for heater
- 17 Starter for separator and pump

Fig. 4 Schematic installation layout of an MMB Separation System.

Standard design MMB 304/305

The MMB 304/305 series are solids-retaining separators that are identical in concept, with different throughput capacities.

Each separator model comprises a frame, power transmission and bowl assembly.

The lower frame houses the flat-belt power transmission unit connected to a vertical drive shaft with friction clutch to the vertical bowl spindle.

The bowl is fixed on top of the spindle inside the space formed by the upper part of the frame and the frame hood.

The frame hood also contains the oil inlet and outlet and the sealing water inlet. The separated water is discharged by gravity through an outlet pipe mounted on the frame.

Basic equipment

- MMB separator.
- Sealing water inlet with hose nipple, non-return valve and constant flow valve with vacuum breaker.
- Set of gravity discs.
- Set of resilient mountings.
- Stainless steel sludge basket.
- Flexible hoses for: oil, water outlet and drain, and sealing water inlet.
- Intermediate service kit.

Additional equipment required for operation

- Electric motor and starter.
- Oil feed pump and starter.
- Set of tools.

Optional equipment

- MAWA-40 water seal alarm unit.
- Pressure switch kit.
- Three-way valve kit.
- Preheater.
- Clarifier disc.
- Major service kit.

Technical data in brief

| | MMB 304 | MMB 305 |
|--|--|---------|
| Input voltage supply: | 220/230, 380/400, 415, 440 V AC (50/60 Hz) | |
| Power consumption at max. rec. flow for gas oil: | 1.4 kW | 2.3 kW |

Shipping data

| | Dimensions (mm) | |
|---|-----------------|---------|
| | MMB 304 | MMB 305 |
| A | 910 | 935 |
| B | 795 | 795 |
| C | 465 | 465 |

| Type of equipment | Weight (kg) | |
|-------------------|-------------|-------|
| | Net | Gross |
| Separator MMB 304 | | |
| – without motor | 185 | 235 |
| – with motor | 201 | 251 |
| Separator MMB 305 | | |
| – without motor | 190 | 240 |
| – with motor | 218 | 268 |

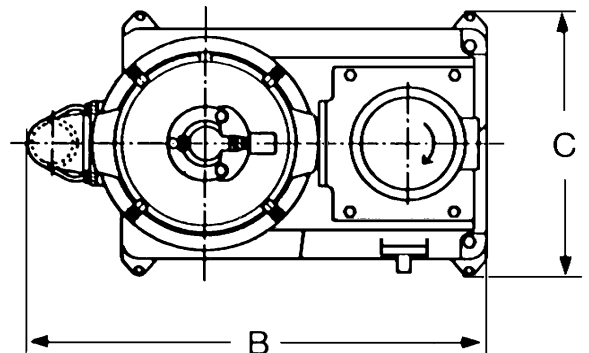
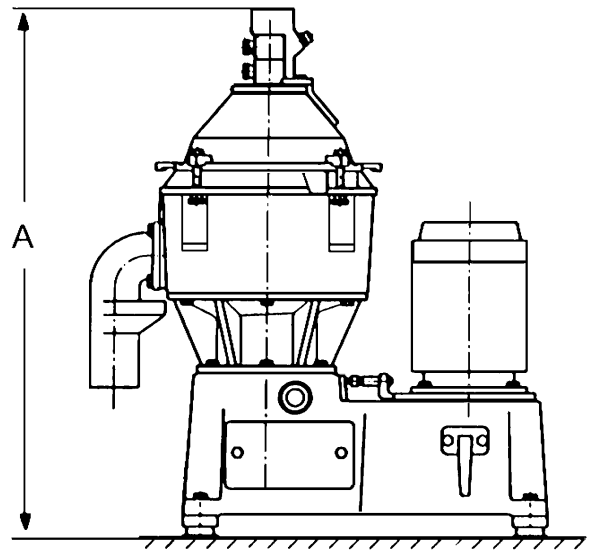

Capacities

The blue bars indicate range from minimum economical throughput on detergent type lubricating oil for trunk diesel engines to a maximum recommended throughput on distillate fuel (1.5–6 cSt/40°C). Detailed information on throughput capacities is provided on separate data sheets for each model.

For more detailed information see the separate data sheet of each model.

MAB/MMB Series Model

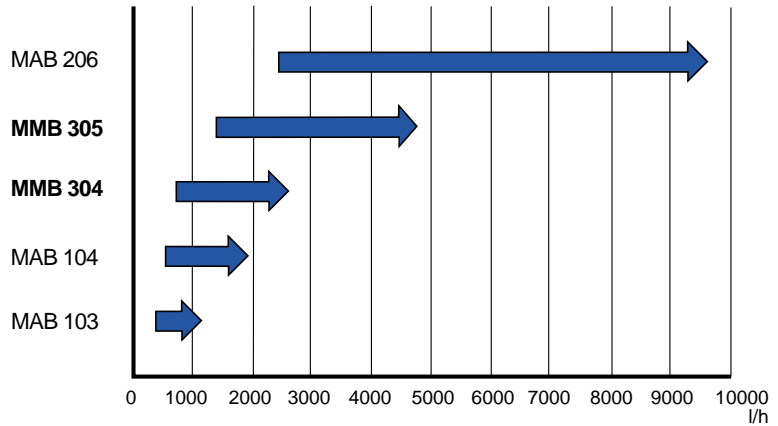

Technical documentation

Complete information and documentation accompany each separator system.

After Sales support

Alfa Laval's Preventive Maintenance Program is available for the MMB 300 series. Alfa Laval service engineers are available to assist you with all types of maintenance and repair, and to help you train your personnel.

The use of genuine Alfa Laval spare parts reduces down-time and repair costs. Spare parts kits can be ordered from Alfa Laval Marine Service Centers and stocked as single units.

Intermediate service kits for routine bowl maintenance and major service kits for bowl overhaul are available.

All service kits include detailed service instructions.

How to contact Alfa Laval

Contact details for all countries are continually updated on our website. Please visit www.alfalaval.com to access the information direct.