

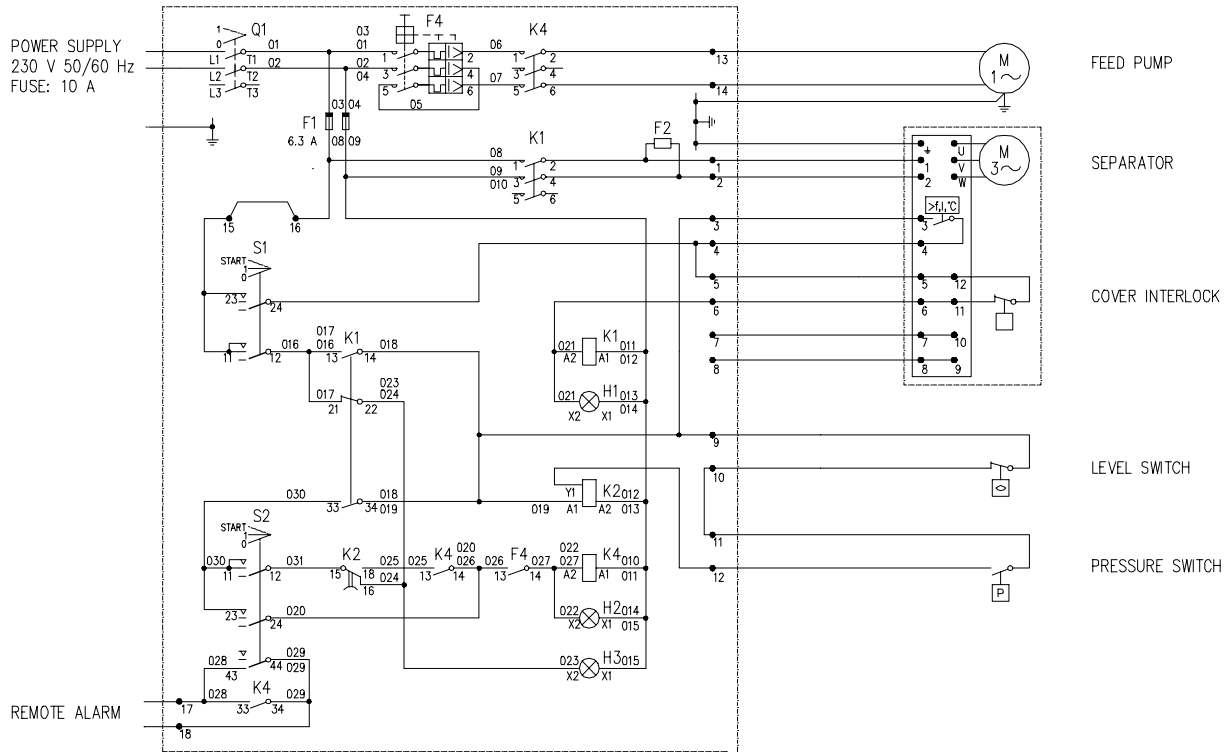

7.5.7.5-1 Circuit diagram 230 V AC



REF. 1764567 REV. 2

X0056565A