



# MAB

## Solids-retaining Centrifugal Separator

### Application

Purification or clarification of mineral oils used in marine installations and power stations (fuel and lubricating oils).

### Working principle

Separation takes place in a solids-retaining bowl that can be arranged for either clarification or purification. In both cases, the contaminated oil is fed into the separator through the centre, and it is separated by centrifugal force into its various phases, the heaviest phase (sludge and water) being forced outwards to the periphery of the bowl. The accumulation of sludge is periodically removed from the bowl by hand.

### Installation

The oil is pumped, heated, and separated as shown in the figure. A liquid seal in the separator bowl prevents the oil from escaping through the water outlet. If this seal is broken, an alarm device is activated. With unmanned engine rooms, the signals are transmitted to a remote control unit. When the seal is broken, the three-way valve shuts off the oil feed and the oil is recirculated until the fault is corrected.



Fig. 1. Separator model MAB 103B complete with feed/discharge pump and fittings for connection to a preheater.

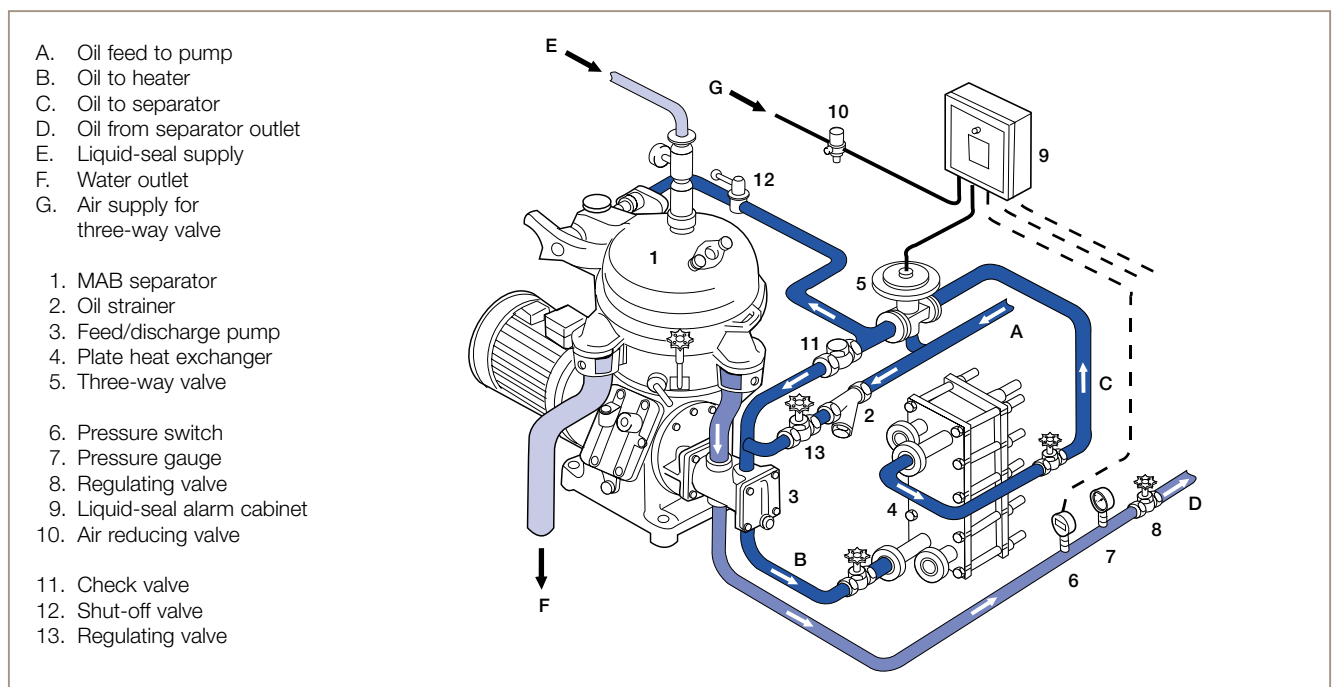

Fig. 2. Schematic installation layout of MAB separator with plate-type oil heater.

1. Oil inlet
2. Clean oil outlet
3. Sludge

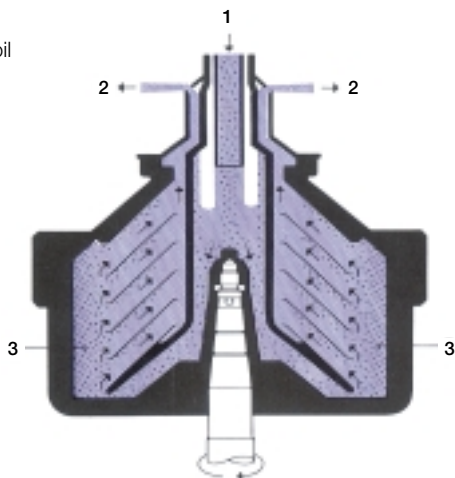

Fig. 3. MAB bowl arranged as a **clarifier** for separating oils containing sludge and a very small quantity of water.

1. Oil inlet
2. Clean oil outlet
3. Sludge
4. Oil/water interface
5. Water outlet

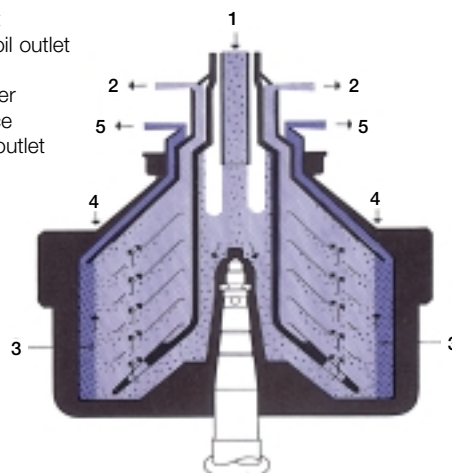

Fig. 4. MAB bowl arranged as a **purifier** for separating oils containing sludge and an appreciable quantity of water.

### Standard design

Solids-retaining separator comprising a frame containing in its lower part a horizontal drive shaft with friction clutch and brake, worm gear and a vertical bowl spindle. The worm gear is placed in an oil bath.

The bowl is fixed on the top of the spindle inside the space formed by the upper part of the frame and the frame hood which also carries the feed and discharge systems. The frame hood is hinged to facilitate easy access for cleaning the bowl which is of the solid-wall disc type.

### Basic equipment

Dirty oil inlet device.  
Clean oil outlet device with sight glass.  
Water outlet spout.  
Liquid seal water inlet.  
Set of gravity discs.

Clarifier parts comprising discharge collar, top disc without neck, and bottom disc without holes.  
Revolution indicator.  
Set of resilient mountings.  
Set of Standard Spare Parts.  
Built-on gear type pump (combined feed/discharge pump).

### Extra equipment

Electric motor.  
Starter.  
Set of tools.  
Set of recommended additional spares for long-time service.  
Flexible connections.  
Preheater.  
Alarm device for broken liquid seal.

### Technical documentation

Complete information and documentation accompany each separator delivery. The installation

Data Manual provides information to ensure correct installation, and the Instruction Book provides separator operators with detailed instructions and advice for obtaining optimal separation.

The Maintenance and Repair Manual describes separator dismantling and reassembly. The Spare Parts Catalogue facilitates the ordering of spare parts.

### Service

Alfa Laval is a worldwide corporation with its head office in Sweden, and affiliated companies and representatives in about 130 countries. Spares and service for all Alfa Laval process equipment are provided through the organization of the Alfa Laval Group and its representatives.

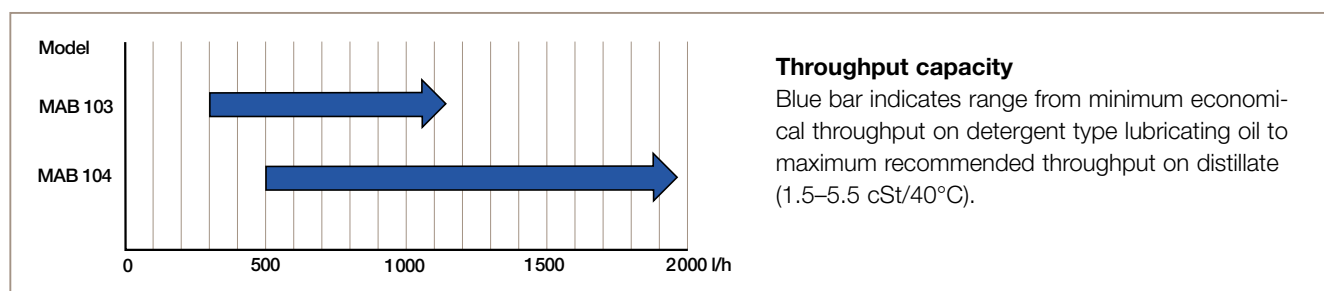

### Throughput capacity

Blue bar indicates range from minimum economical throughput on detergent type lubricating oil to maximum recommended throughput on distillate (1.5–5.5 cSt/40°C).

340-PD1en-0106

### How to contact Alfa Laval

Contact details for all countries are continually updated on our website. Please visit [www.alfalaval.com](http://www.alfalaval.com) to access the information direct.